

MODEL L-8

INSTALLATION INSTRUCTION SHEET

HARWIL CORPORATION

541 KINETIC DRIVE, OXNARD, CA 93030

TEL: (805) 988-6800 FAX: (805) 988-6804

EMAIL: HARWIL@HARWIL.COM

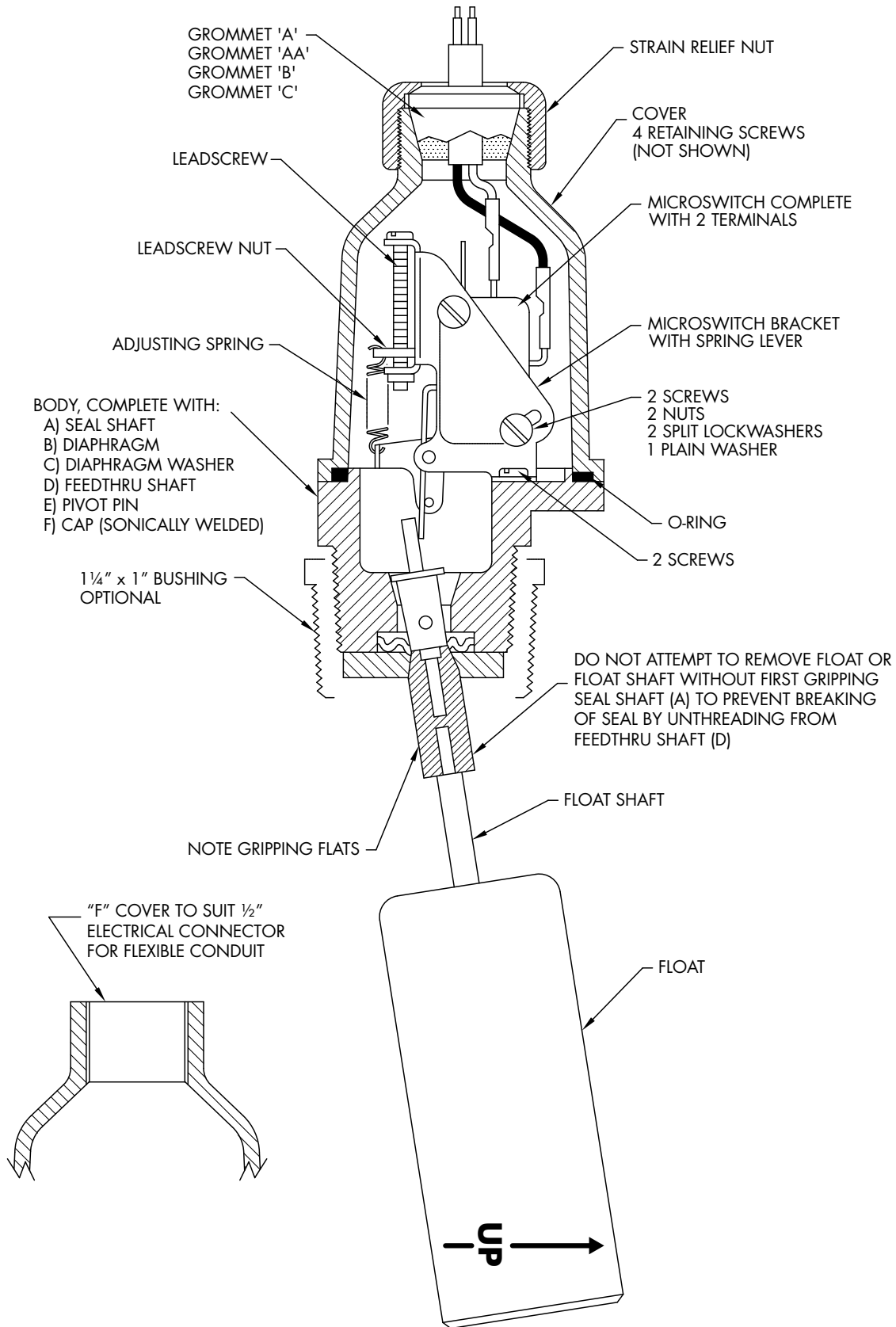

MODEL L-8

HARWIL CORPORATION

541 KINETIC DRIVE, OXNARD, CA 93030
 TEL: (805) 988-6800 FAX: (805) 988-6804
 EMAIL: HARWIL@HARWIL.COM

SPECIFICATIONS

(Same for all models except where shown)

MODEL L-8N

Noryl body, float and bushing; Hypalon diaphragm, 316 stainless steel float shaft and screws.

FOR

Mild acids and bases, inorganics, some alcohols, some hydrocarbons, water, etc.

WORKING FLUID SPECIFIC GRAVITY RANGE ADJUSTABLE BETWEEN 0.6 AND 1.5 AND UP.

NOMINAL WORKING TEMPERATURE/PRESSURE:

180°F at 75 psig

LIQUID LEVEL CHANGE TO ACTIVATE SWITCH: $\approx 1/4"$

max. travel

WEIGHT: 0.5 lb.

MODEL L-8R

Fortron (PPS) body, float, and bushing; Viton diaphragm, 316 stainless steel float shaft and screws.

FOR

Medium acids and bases, inorganics, alcohols, most hydrocarbons.

MODEL L-8CR

Fortron (PPS) body, float, and bushing; Viton diaphragm, Hastelloy C float shaft, and Teflon screws.

FOR

Concentrated acids and bases, inorganics, alcohols, hydrocarbons, chlorinated organics, phenols, etc.

ELECTRICAL SWITCH CHARACTERISTICS

- SPDT
- UL and CSA listed
- 15 AMP, 1/2 HP at 125 or 250 VAC
- 1/2 AMP at 125 VDC, 1/4 AMP at 250 VDC
- 5 AMP at 125 VAC (Tungsten lamp load)
- 10,000,000 mechanical operations median

SPDT-DRY CIRCUIT UL & CSA LISTED

Gold cross bar contacts for computer/PLC interface.
 1.0 AMP or less, 5–24 VAC/DC

INSTALLATION DIMENSIONS

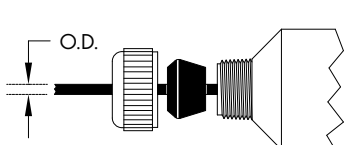
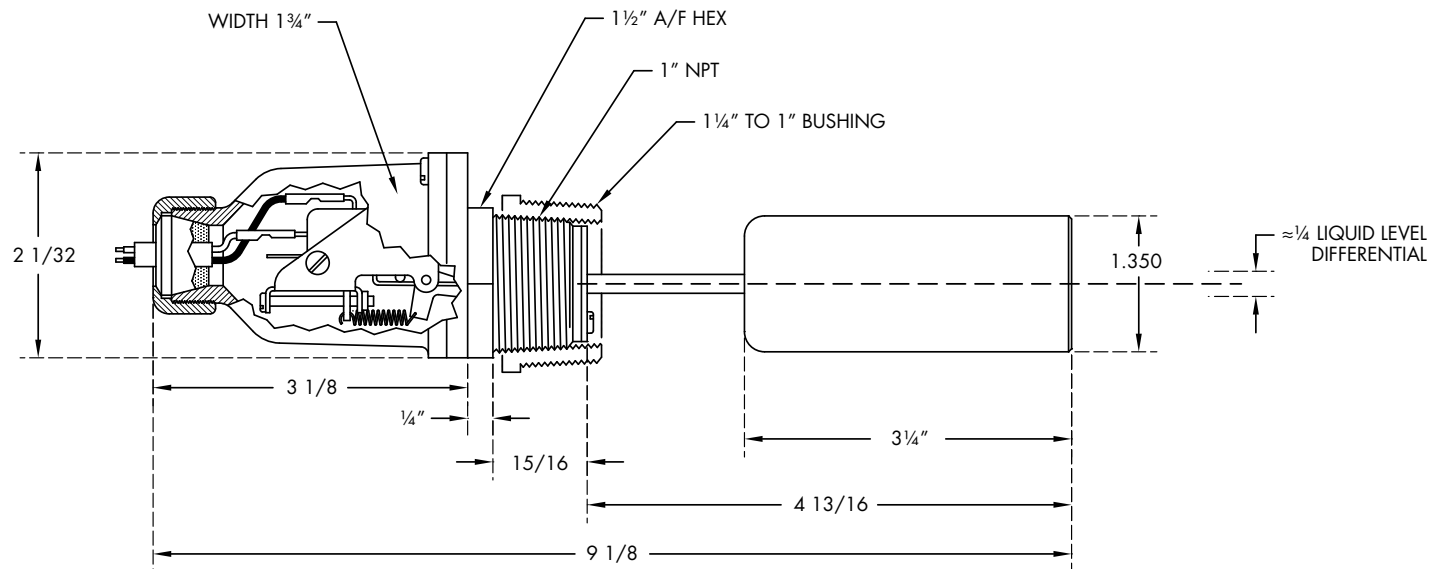

Grommet Size	Cable OD	Grommet Size	Cable OD
A	0.25"	B	0.37"
AA	0.30"	C	0.50"

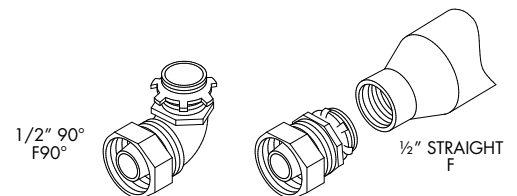

MODEL L-8

HARWIL CORPORATION

541 KINETIC DRIVE, OXNARD, CA 93030

TEL: (805) 988-6800 FAX: (805) 988-6804

EMAIL: HARWIL@HARWIL.COM

ELECTRICAL WIRING

Model L-8 is supplied with a strain relief cable fitting for use with round or plastic jacketed power cable.

1. Remove strain relief nut, grommet, and cover.
2. Strip the outer jacket of the cord back approximately 1 ¼", stagger ½", and strip leads ¼".

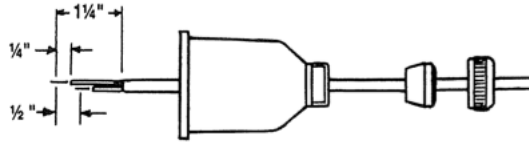

3. Remove slip-on connectors from microswitch and crimp or solder to the leads.
4. Feed the cable through the strain relief nut, grommet, and cover.

NOTE: Check match of outside diameter of cable with inside diameter of grommet. No more than 0.20" of play should be evident.

5. Apply slip-on connectors to appropriate terminals of the microswitch. Slide the cover down the cable and fasten it to the body with four screws. Slide the grommet down the cable until the small end is level with the outer jacket. Push the grommet into the tapered hole of the cover, hold the jacket to prevent rotation, and tighten the strain relief nut firmly.

Model L-8 supplied with "F" Cover

"F" Cover allows the use of standard ½" electrical connectors to suit flexible conduits, such as Sealflex, plastic Spiraduct, etc. Attach slip-on connectors to leads and appropriate terminals of microswitch and complete wiring to electrical code.

Microswitch activation may be monitored by an audible click or with an ohmmeter prior to connecting line power to the switch terminals, or by monitoring the voltage supplied to the load through the microswitch.

Fig 1: Wiring schematic for power applied to load when liquid level is less than set point (power to load interrupted when level increases to above set point).

Decreasing liquid level moves actuator in direction shown.

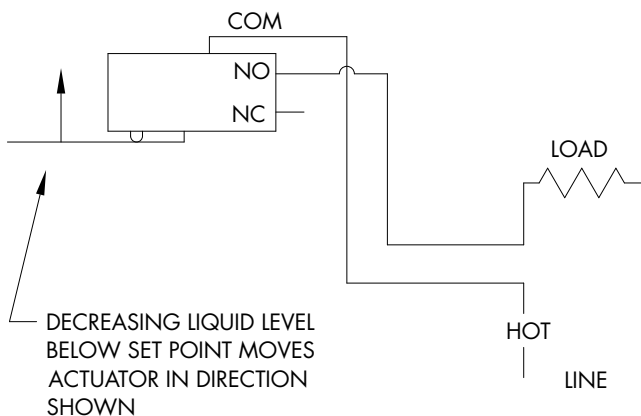
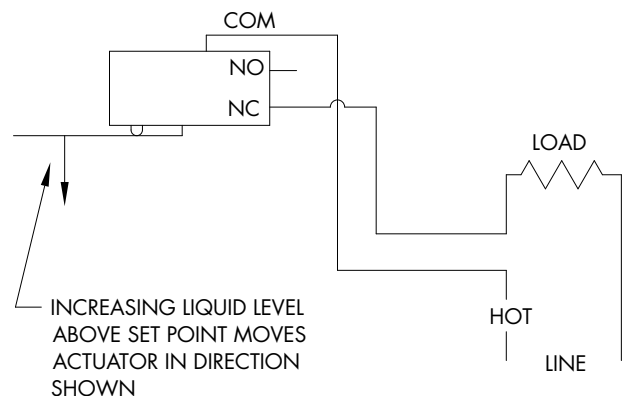

Fig 2: Wiring schematic for power applied to load when liquid level is greater than set point (power to load interrupted when level decreases to below set point).

Increasing liquid level moves actuator in direction shown.



MODEL L-8

HARWIL CORPORATION

541 KINETIC DRIVE, OXNARD, CA 93030

TEL: (805) 988-6800 FAX: (805) 988-6804

EMAIL: HARWIL@HARWIL.COM

Model L-8 liquid level switch is provided with a continuous adjustable float buoyancy control to allow use in fluids with specific gravity down to 0.6.

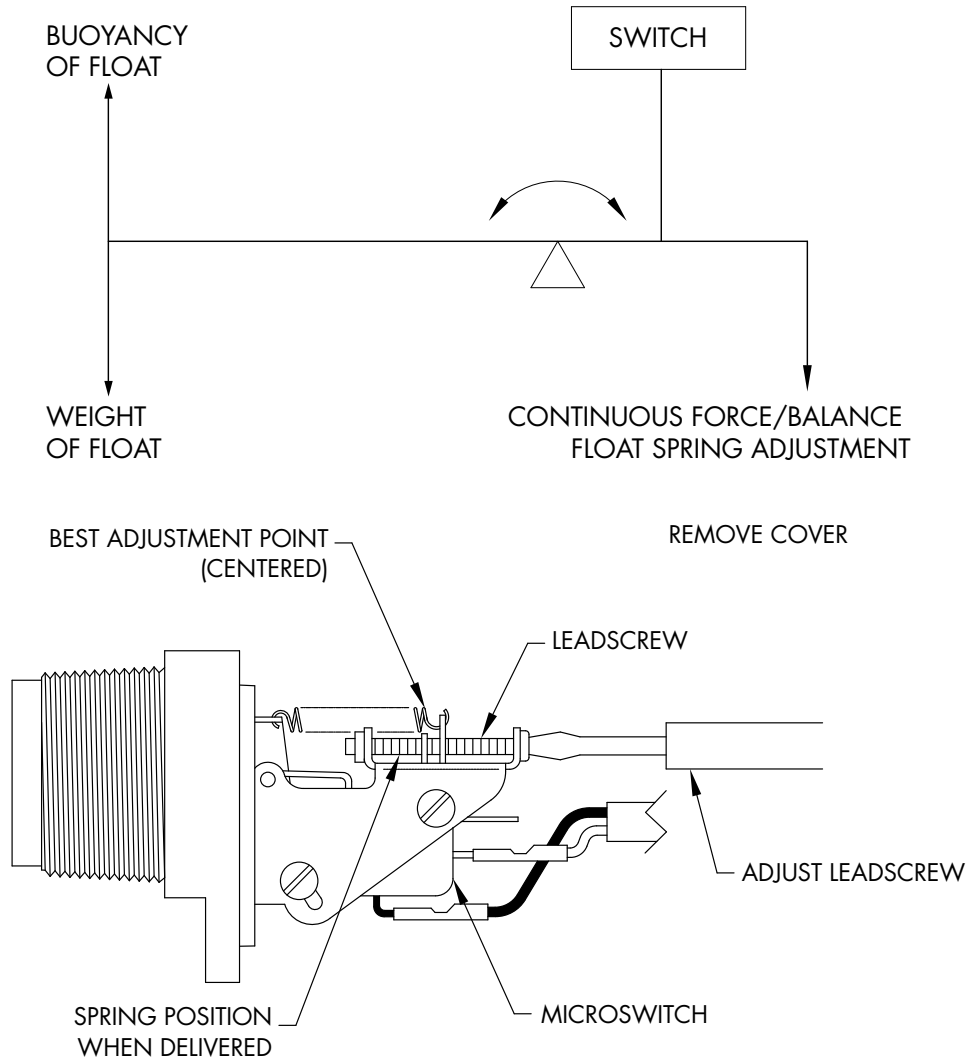

SWITCH POINT ADJUSTMENT

1. Remove cover.
2. All units are delivered with the spring in the fully relaxed condition (A), which corresponds to the maximum specific fluid condition.

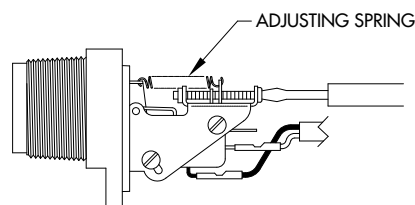

3. Insert blade type screw driver in the slotted end of the adjusting screw and turn it in a clockwise direction. This extends the length of the adjusting spring, which in turn adjusts the float net effective buoyancy to respond to lower specific gravity fluids.

MODEL L-8

HARWIL CORPORATION

541 KINETIC DRIVE, OXNARD, CA 93030

TEL: (805) 988-6800 FAX: (805) 988-6804

EMAIL: HARWIL@HARWIL.COM

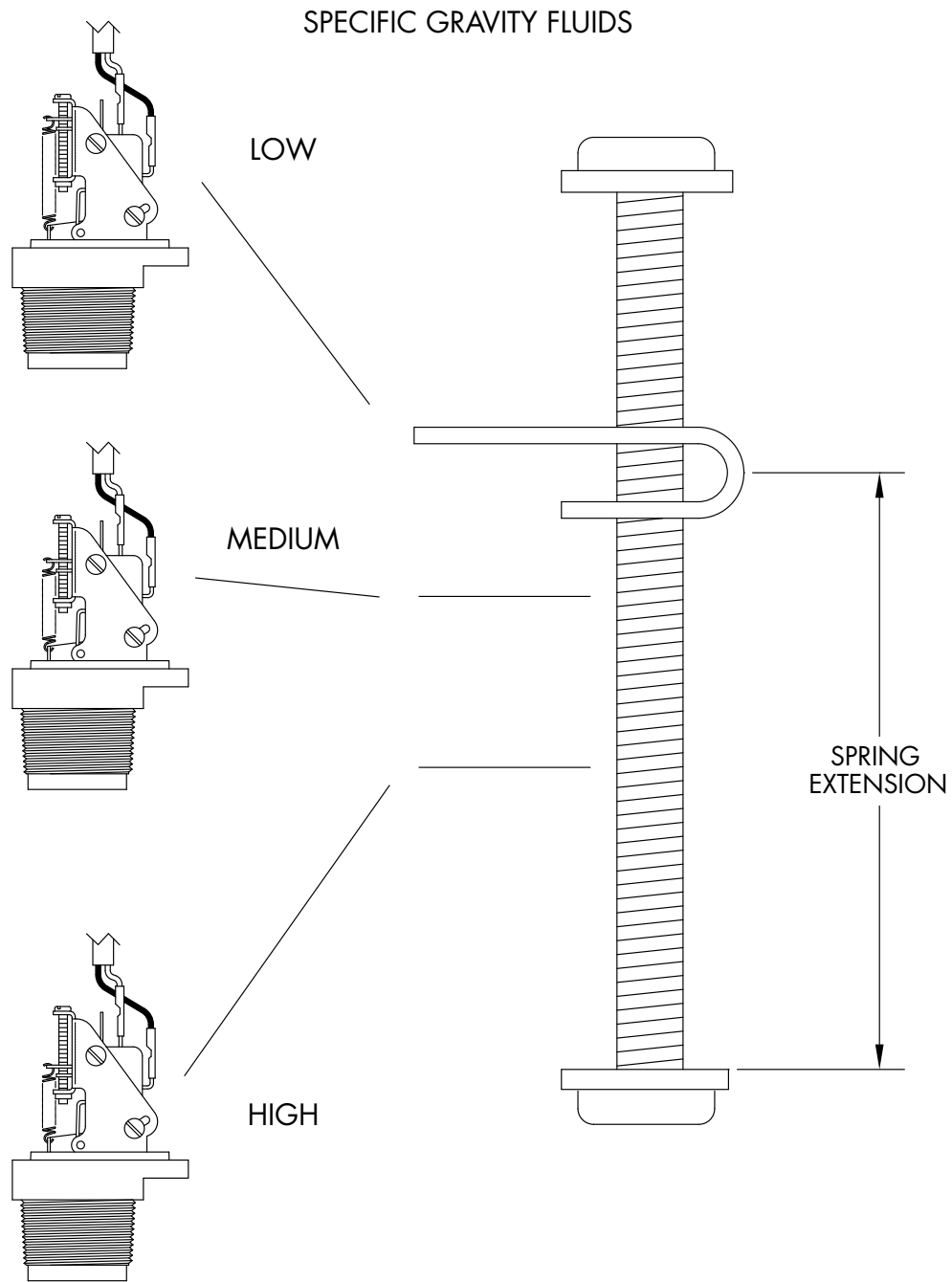

Microswitch actuation point may be monitored during the adjustment procedure detailed in (2 and 3) above by an audible click or with an ohmmeter before connecting line power to the terminal strip, or by monitoring the voltage supplied to the load through the microswitch.

MODEL L-8

HARWIL CORPORATION

541 KINETIC DRIVE, OXNARD, CA 93030

TEL: (805) 988-6800 FAX: (805) 988-6804

EMAIL: HARWIL@HARWIL.COM

L-8N (Series 65600)

#	PART NAME	QTY	PART #	#	PART NAME	QTY	PART #
1	STRAIN RELIEF NUT	(1)	60127	13	WASHER	(2)	301-W
2	GROMMET			14	SCREW	(2)	118-S
	#A (OPTIONAL)	(1)	10440	15	LEAD SCREW NUT	(1)	65214
	#AA (OPTIONAL)	(1)	10441	16	SPRING	(1)	65202
	#B (OPTIONAL)	(1)	10442	17	SCREW	(2)	123-S
	#C (OPTIONAL)	(1)	10443	18	O-RING	(1)	65110
3	COVER (MALE) (OPTIONAL)	(1)	60125	19	BODY (ASSEMBLY ONLY)	(1)	65203
4	COVER (FEMALE) (OPTIONAL)	(1)	60126		CLAMP RING (SONIC WELD)	(1)	65102
5	SCREW	(4)	109-S	20	BUSHING REDUCER (OPTIONAL)	(1)	65204
6	MICROSWITCH	(1)	20103		BUSHING REDUCER (OPTIONAL)	(1)	65205
7	BRACKET (COMPLETE ASSEMBLY)	(1)	65201	21	FEED THRU SHAFT (ASSEMBLY ONLY)	(1)	65103
	#A CROSS PIN	(1)	65215		A) SEAL SHAFT	(1)	65104
	#B SPRING LEVER	(1)	65216		B) DIAPHRAGM	(1)	65105
8	TERMINALS	(3)	706-T		C) DIAPHRAGM WASHER	(1)	65106
9	SCREW	(1)	133-S		D) PIVOT PIN	(1)	65107
10	SCREW	(1)	116-S		E) CROSS PIN	(1)	65108
11	NUT	(2)	219-N	22	FLOAT SHAFT ARM #2-B	(1)	65208
12	WASHER	(2)	311-W	23	FLOAT (FORTRON)	(1)	65601
				24	FLOAT (POLYPROPYLENE) (OPTIONAL)	(1)	65602

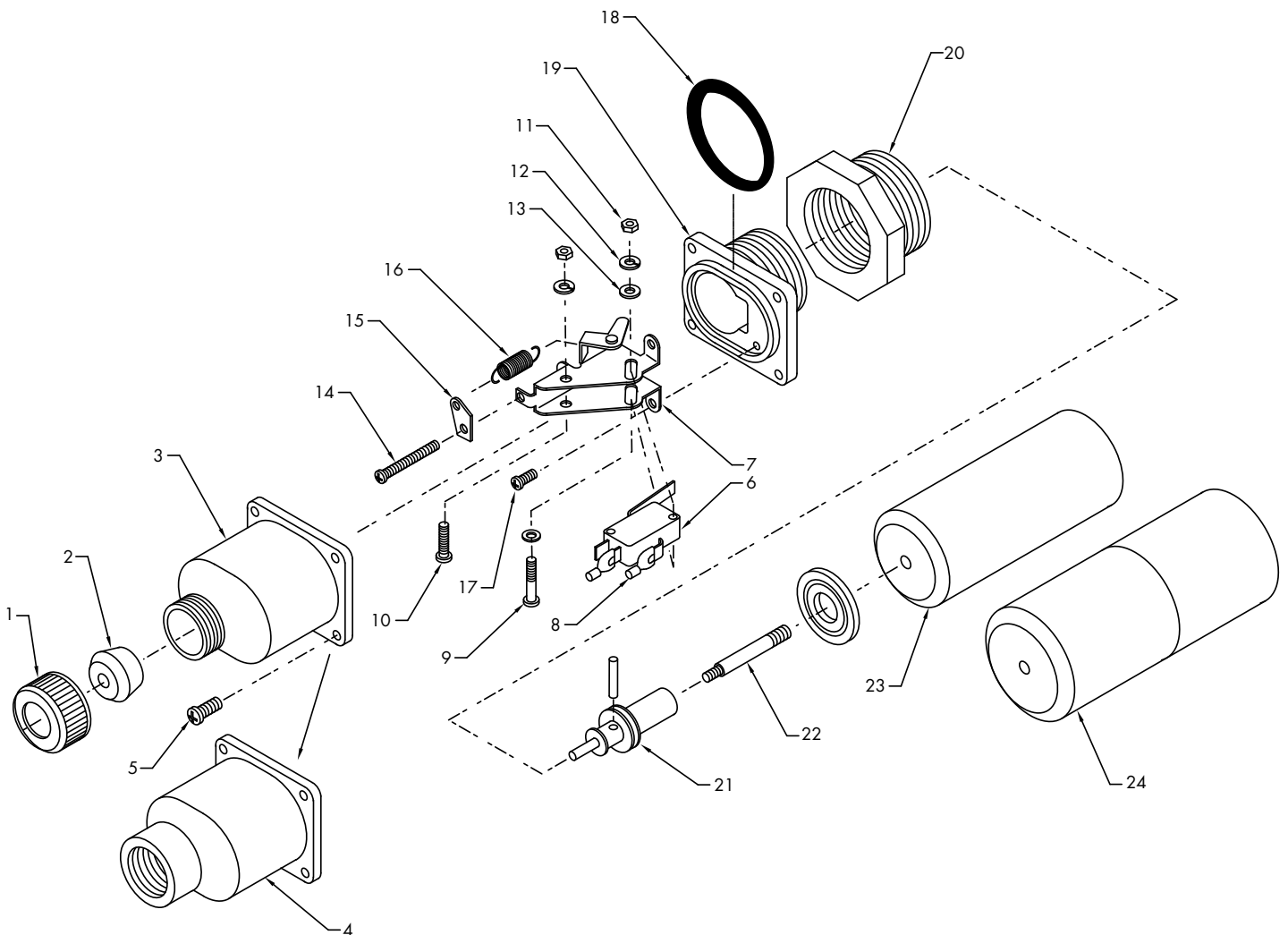

MODEL L-8

HARWIL CORPORATION

541 KINETIC DRIVE, OXNARD, CA 93030

TEL: (805) 988-6800 FAX: (805) 988-6804

EMAIL: HARWIL@HARWIL.COM

L-8R (Series 65800)

#	PART NAME	QTY	PART #	#	PART NAME	QTY	PART #
1	STRAIN RELIEF NUT	(1)	65301	13	WASHER	(2)	301-W
2	GROMMET			14	SCREW	(2)	118-S
	#A (OPTIONAL)	(1)	10440	15	LEAD SCREW NUT	(1)	65214
	#AA (OPTIONAL)	(1)	10441	16	SPRING	(1)	65202
	#B (OPTIONAL)	(1)	10442	17	SCREW	(2)	123-S
	#C (OPTIONAL)	(1)	10443	18	O-RING	(1)	65110
3	COVER (MALE) (OPTIONAL)	(1)	65302	19	BODY (ASSEMBLY ONLY)	(1)	65304
4	COVER (FEMALE) (OPTIONAL)	(1)	65303		CLAMP RING (SONIC WELD)	(1)	65305
5	SCREW	(4)	109-S	20	BUSHING REDUCER (OPTIONAL)	(1)	65306
6	MICROSWITCH	(1)	20103		BUSHING REDUCER (OPTIONAL)	(1)	65307
7	BRACKET (COMPLETE ASSEMBLY)	(1)	65201	21	FEED THRU SHAFT (ASSEMBLY ONLY)	(1)	65103
	#A CROSS PIN	(1)	65215		A) SEAL SHAFT	(1)	65104
	#B SPRING LEVER	(1)	65216		B) DIAPHRAGM	(1)	65105
8	TERMINALS	(3)	706-T		C) DIAPHRAGM WASHER	(1)	65106
9	SCREW	(1)	133-S		D) PIVOT PIN	(1)	65107
10	SCREW	(1)	116-S		E) CROSS PIN	(1)	65108
11	NUT	(2)	219-N	22	FLOAT SHAFT ARM #2-B	(1)	65208
12	WASHER	(2)	311-W	23	FLOAT (FORTRON)	(1)	65601
				24	FLOAT (POLYPROPYLENE) (OPTIONAL)	(1)	65602

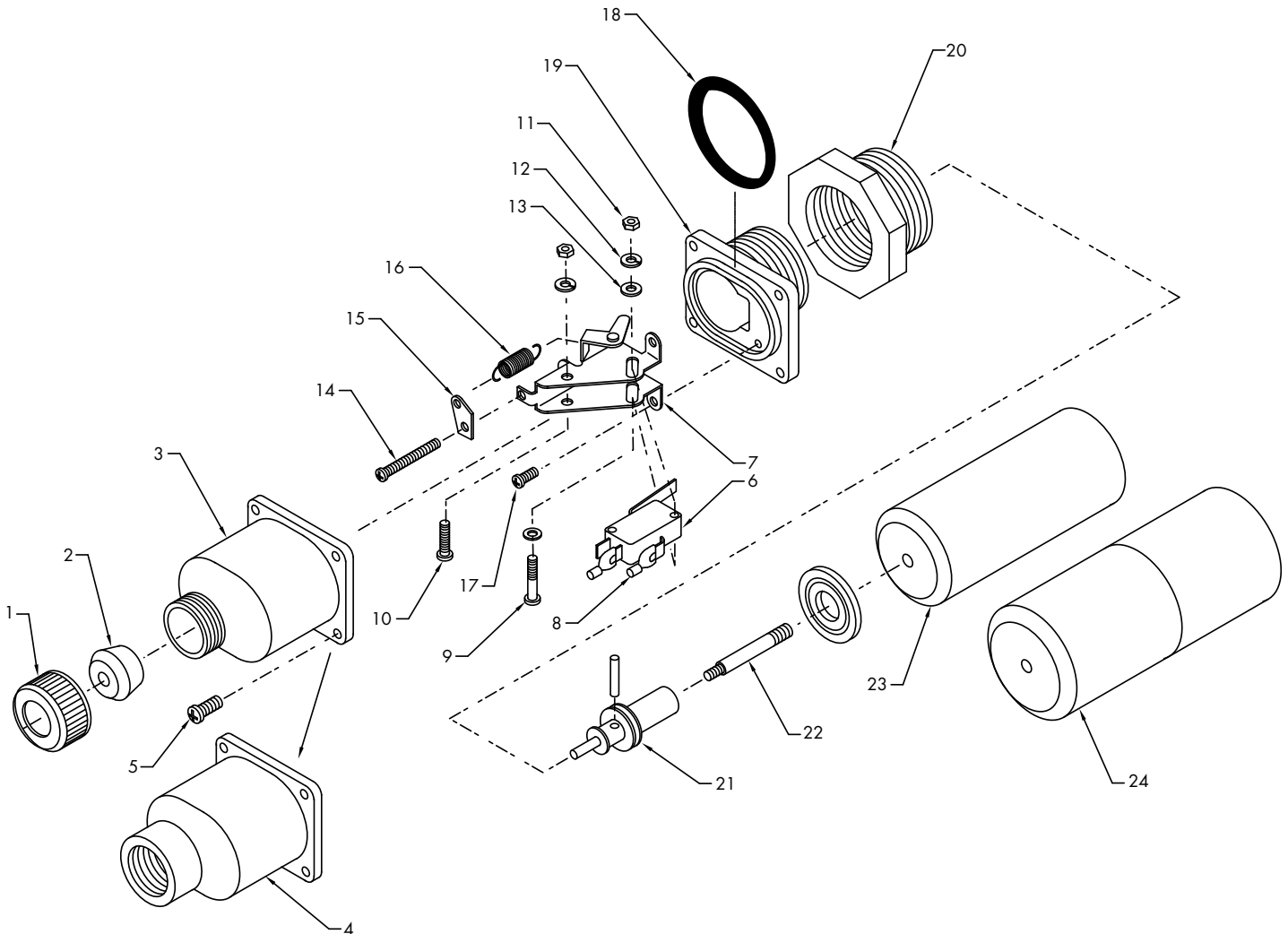

MODEL L-8

HARWIL CORPORATION

541 KINETIC DRIVE, OXNARD, CA 93030

TEL: (805) 988-6800 FAX: (805) 988-6804

EMAIL: HARWIL@HARWIL.COM

L-8CR (Series 65900)

#	PART NAME	QTY	PART #	#	PART NAME	QTY	PART #
1	STRAIN RELIEF NUT	(1)	60127	13	WASHER	(2)	301-W
2	GROMMET			14	SCREW	(2)	118-S
	#A (OPTIONAL)	(1)	65701	15	LEAD SCREW NUT	(1)	65214
	#AA (OPTIONAL)	(1)	65702	16	SPRING	(1)	65202
	#B (OPTIONAL)	(1)	65703	17	SCREW	(2)	123-S
	#C (OPTIONAL)	(1)	65704	18	O-RING	(1)	65110
3	COVER (MALE)	(1)	65302	19	BODY (ASSEMBLY ONLY)	(1)	65304
4	COVER (FEMALE)	(1)	65303		CLAMP RING (SONIC WELD)	(1)	65305
5	SCREW	(4)	109-S	20	BUSHING REDUCER (OPTIONAL)	(1)	65306
6	MICROSWITCH	(1)	20103		BUSHING REDUCER (OPTIONAL)	(1)	65307
7	BRACKET (COMPLETE ASSEMBLY)	(1)	65201	21	FEED THRU SHAFT (ASSEMBLY ONLY)	(1)	65103
	#A CROSS PIN	(1)	65215		A) SEAL SHAFT	(1)	65104
	#B SPRING LEVER	(1)	65216		B) DIAPHRAGM	(1)	65105
8	TERMINALS	(3)	706-T		C) DIAPHRAGM WASHER	(1)	65106
9	SCREW	(1)	133-S		D) PIVOT PIN	(1)	65107
10	SCREW	(1)	116-S		E) CROSS PIN	(1)	65108
11	NUT	(2)	219-N	22	FLOAT SHAFT ARM #2-B	(1)	65708
12	WASHER	(2)	311-W	23	FLOAT (FORTRON)	(1)	65805
				24	FLOAT (POLYPROPYLENE) (OPTIONAL)	(1)	65602

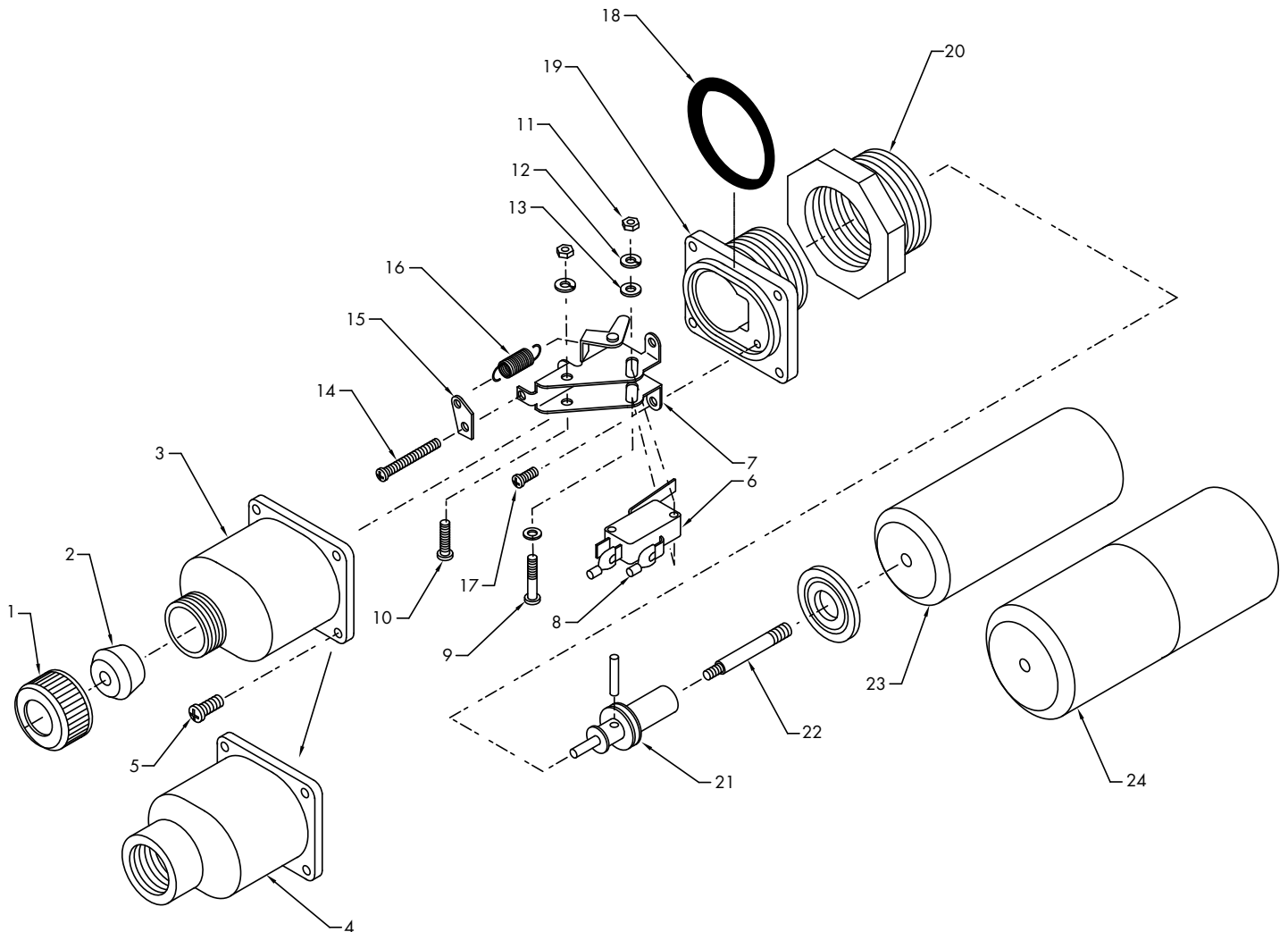

CERTIFICATE OF CONFORMANCE

All Harwil Corporation ("HARWIL") products are manufactured using new materials and components. Our products meet the applicable performance and materials specifications indicated in our current Specifications Sheets and Parts List. HARWIL endeavors to obtain its materials and components from American Companies.

DOMINANCE OF HARWIL LIMITED EXPRESS WARRANTY

Each user **MUST** make appropriate analysis and tests to determine the suitability of the HARWIL product for the intended use prior to purchase.

HARWIL warrants that all HARWIL products will be free from defects in material and workmanship for a period of one year from the date of original shipment. This Warranty shall be LIMITED to the replacement and reconditioning of our products and parts. HARWIL reserves the right and sole discretion to modify or change the composition, design and appearance of its products at anytime.

THIS WARRANTY SHALL BE IN LIEU OF ALL WARRANTIES OF MERCHANTABILITY AND OF ALL WARRANTIES OF FITNESS FOR A PARTICULAR PURPOSE RELATING TO HARWIL PRODUCTS AND PARTS. BUYER'S SOLE REMEDY SHALL BE REPLACEMENT OR RECONDITIONING AS SET FORTH HEREIN.

HARWIL SHALL INCUR NO OBLIGATIONS HEREUNDER AND NO LIABILITY IN THE EVENT OF (1) BUYER NOT FULFILLING ITS RESPONSIBILITIES; INCLUDING AS SET FORTH HEREIN; (2) NEGLIGENCE, ALTERATION OR IMPROPER PRODUCT USE, INCLUDING USE WITH NON-COMPATIBLE DEVICES OR CHEMICALS; OR (3) REPAIR BY ANOTHER COMPANY OR PERSON THAN HARWIL.

ANY LAWSUIT RELATING TO THIS LIMITED EXPRESS WARRANTY MUST BE COMMENCED WITHIN ONE YEAR OF THE DATE THE LAWSUIT ACCRUES.

HARWIL provides NO WARRANTY and ASSUMES NO RESPONSIBILITY for corrosive attack on any material, component or design features associated with any of its products.

Corrosion resistance information listed in HARWIL specification sheets, information sheets and product brochures is solely for general background information. This information table has been compiled from literature published by various material suppliers and by equipment manufacturers who use these materials in their products. Inasmuch as these data are based on tests by entities over which HARWIL has no control, HARWIL DOES NOT GUARANTEE AND DOES NOT ACCEPT ANY RESPONSIBILITY FOR THE ACCURACY OF SUCH THIRD PARTY TESTING. When using the table, please remember that in any given case several factors such as concentration, temperature, degrees of agitation and presence of impurities influence the rate of corrosion. The information table is intended, in a general way, to rate materials for resistance to chemicals which contain their usual impurities and for types of equipment in common use. Ratings should be used only as a general tool to first approximation of your material requirements rather than as the final answer.

WHEN IN DOUBT, TEST MATERIALS BEFORE INSTALLATION.
AFTER INSTALLATION, FOLLOW UP WITH SCHEDULED PREVENTATIVE MAINTENANCE AND PERIODIC INSPECTION.