

MODEL L-21

INSTALLATION INSTRUCTION SHEET

HARWIL CORPORATION

541 KINETIC DRIVE, OXNARD, CA 93030

TEL: (805) 988-6800 FAX: (805) 988-6804

EMAIL: HARWIL@HARWIL.COM

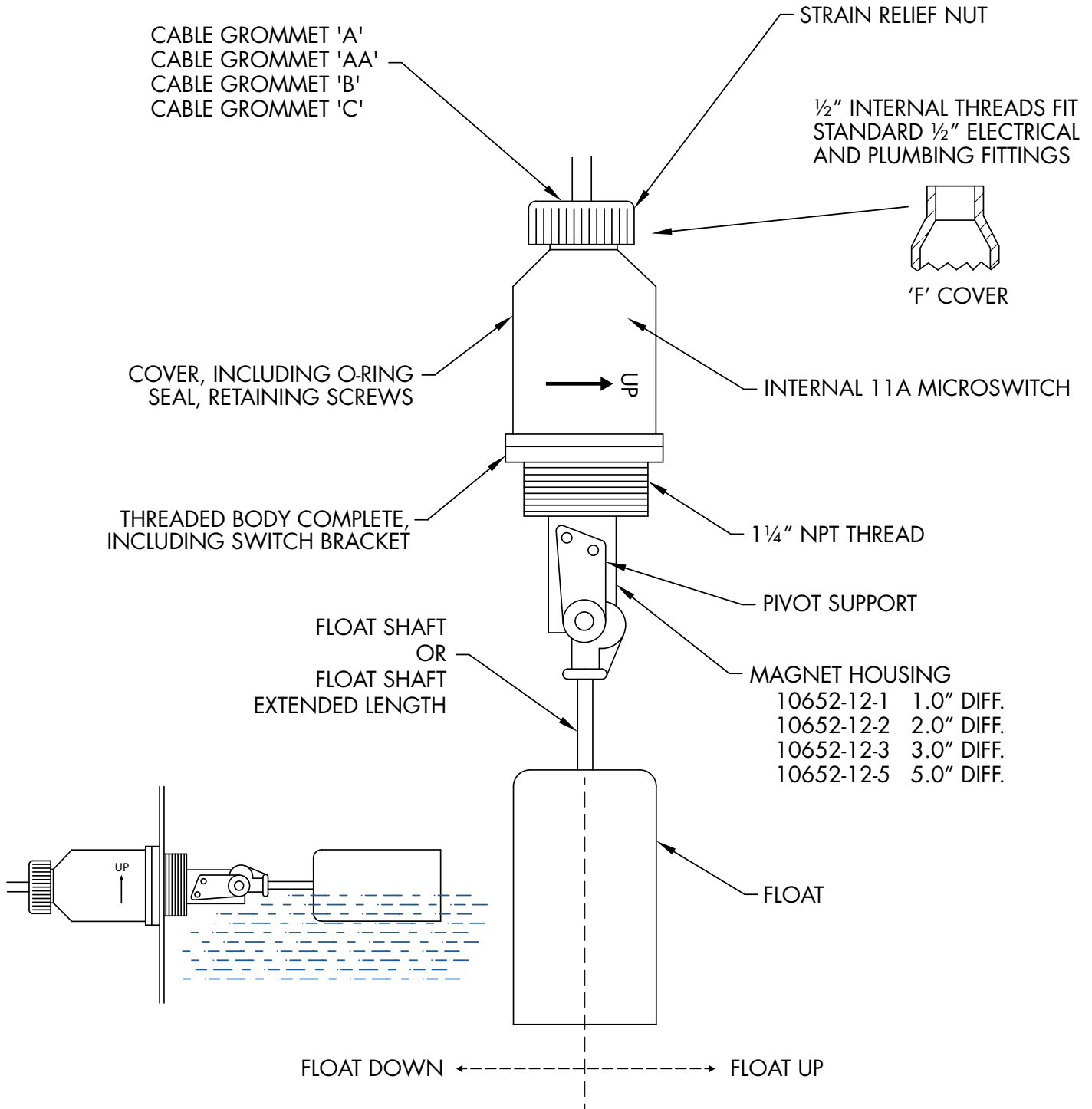

MODEL L-21

HARWIL CORPORATION

541 KINETIC DRIVE, OXNARD, CA 93030
 TEL: (805) 988-6800 FAX: (805) 988-6804
 EMAIL: HARWIL@HARWIL.COM

INSTALLATION AND OPERATING INSTRUCTIONS

1. If the shipping container and contents are received damaged, immediately call the shipping company for damage inspection and file the appropriate report, sending a copy to Harwil Corp. for product replacement and insurance adjustment.
2. If the contents are not damaged, inspect the units received against the packing list and the original purchase order. If incorrect units are received, call Harwil Corp. immediately for resolution of the problem.
3. Check for damage or scuffing on the Teflon tape applied to the 1 1/4" NPT threads of the switch body. Re-tape as required with 2 to 3 layers wound clockwise (looking at the end of the threaded body with the float toward the viewer).
4. Remove the cover and check switch action with a multimeter while moving the float up and down.

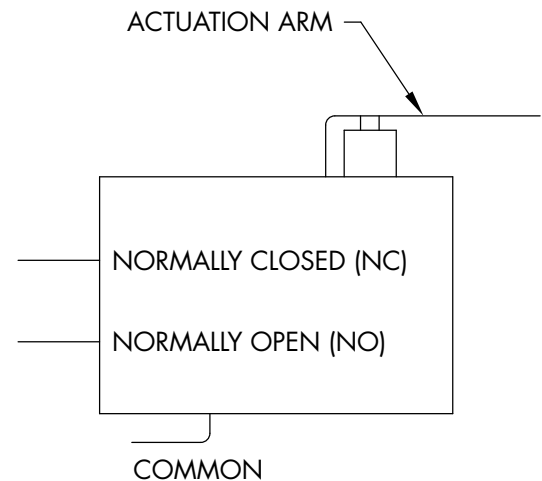

FLOAT UP/DOWN CONFIGURATION

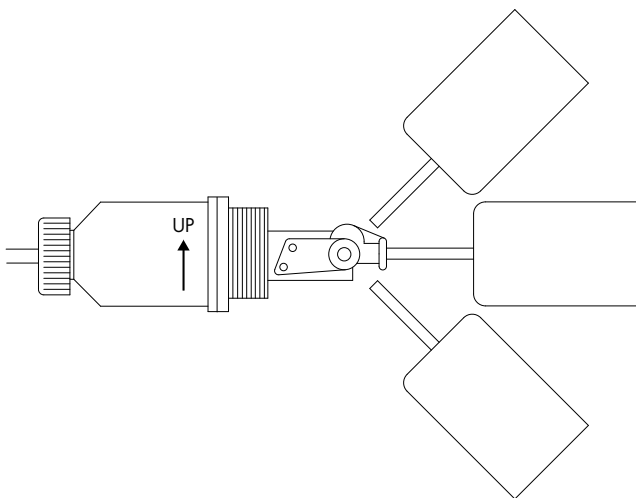

FLOAT POSITION	MULTIMETER CONNECTION	METER READING
UP	COMM. AND NO TERMINALS	CONTINUITY
	COMM. AND NC TERMINALS	OPEN CIRCUIT
DOWN	COMM. AND NO TERMINALS	OPEN CIRCUIT
	COMM. AND NC TERMINALS	CONTINUITY

5. Replace the domed cover on the unit and insert the float through the 1 1/4" NPT hole in the tank. Mate the switch body threads with tank threads and tighten with an appropriate wrench until the thread joint is leak-tight and the arrow on the cover label is pointing vertically upward.

NOTE: Model L-21 can be supplied with 1 1/2" x 1 1/4" or larger reducer bushings as required to fit existing large holes in a tank wall.

6. Remove the cover and wire as indicated on page 3.

MODEL L-21

HARWIL CORPORATION

541 KINETIC DRIVE, OXNARD, CA 93030

TEL: (805) 988-6800 FAX: (805) 988-6804

EMAIL: HARWIL@HARWIL.COM

LOW LIQUID LEVEL ALARM

Fig 1: Wiring schematic for power applied to load when liquid level is less than set point (power to load interrupted when level increases to above set point).

Decreasing liquid level moves actuator in direction shown.

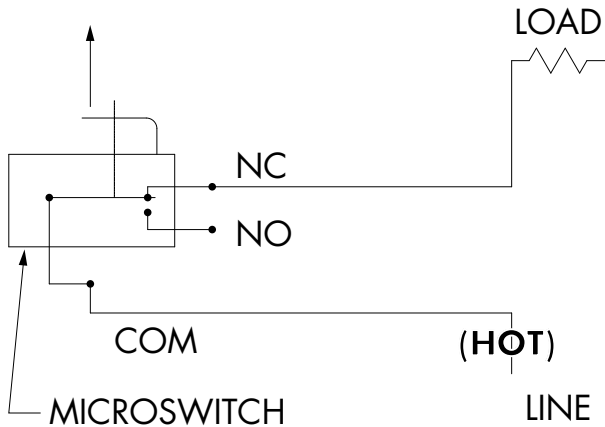

HIGH LIQUID LEVEL ALARM

Fig 2: Wiring schematic for power applied to load when liquid level is greater than set point (power to load interrupted when level decreases to below set point).

Increasing liquid level moves actuator in direction shown.

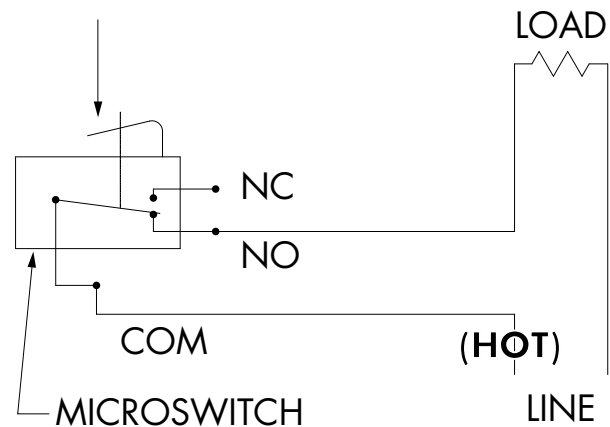

Microswitch actuation point may be monitored by an audible click or with an ohmmeter before connecting line power to the switch terminals or by monitoring the voltage supplied to the load through the microswitch.

* **Pump Up** wiring diagram same as low level alarm shown in Fig. 1

* **Pump Down** wiring diagram same as high level alarm shown in Fig. 2

* **Electrical Wiring** (Strain Relief Grommet):

Step 1) Remove the gland nut, grommet, and switch cover.

Step 2) Strip the outer jacket of the electrical cord back approximately 1 ¼" (inches). Strip insulation from individual conductors back approximately ¼" (inch).

Step 3) Slip-on terminals are supplied with each switch.

Remove from switch terminals and crimp on or solder to electrical leads.

Step 4) Feed the electrical cable through the strain relief nut, grommet, and switch cover.

Step 5) Apply slip-on terminals to appropriate contacts of microswitch. Slide cover down the cable and fasten it to the body of the switch with four (4) screws provided. Slide grommet down the cable and push the grommet into the tapered end of the cover. Hold the cable jacket to prevent rotation and thread gland nut firmly onto cover.

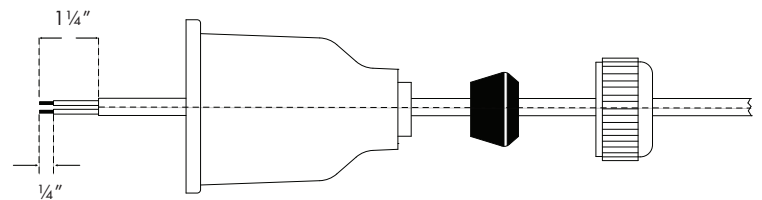

* **Electrical Wiring** ('F' Cover):

Step 1) Remove switch cover.

Step 2) Strip the outer jacket of the electrical cord back approximately 1 ¼" (inches). Strip insulation from individual conductors back approximately ¼" (inch).

Step 3) Slip-on terminals are supplied with each switch. Remove from switch terminals and crimp on or solder to electrical leads.

Step 4) Thread user supplied ½" flexible conduit fitting into ½" female thread on end of cover. Feed electrical

cable through conduit fitting.

Step 5) Apply slip-on terminals to appropriate male spade contacts on microswitch. Slide cover down cable and fasten to body of switch with four (4) screws provided. Be sure to install the "O" ring between the body and cover. Connect flexible ½" metal or plastic conduit-to-conduit fitting on end of cover per standard procedure.

MODEL L-21

HARWIL CORPORATION

541 KINETIC DRIVE, OXNARD, CA 93030

TEL: (805) 988-6800 FAX: (805) 988-6804

EMAIL: HARWIL@HARWIL.COM

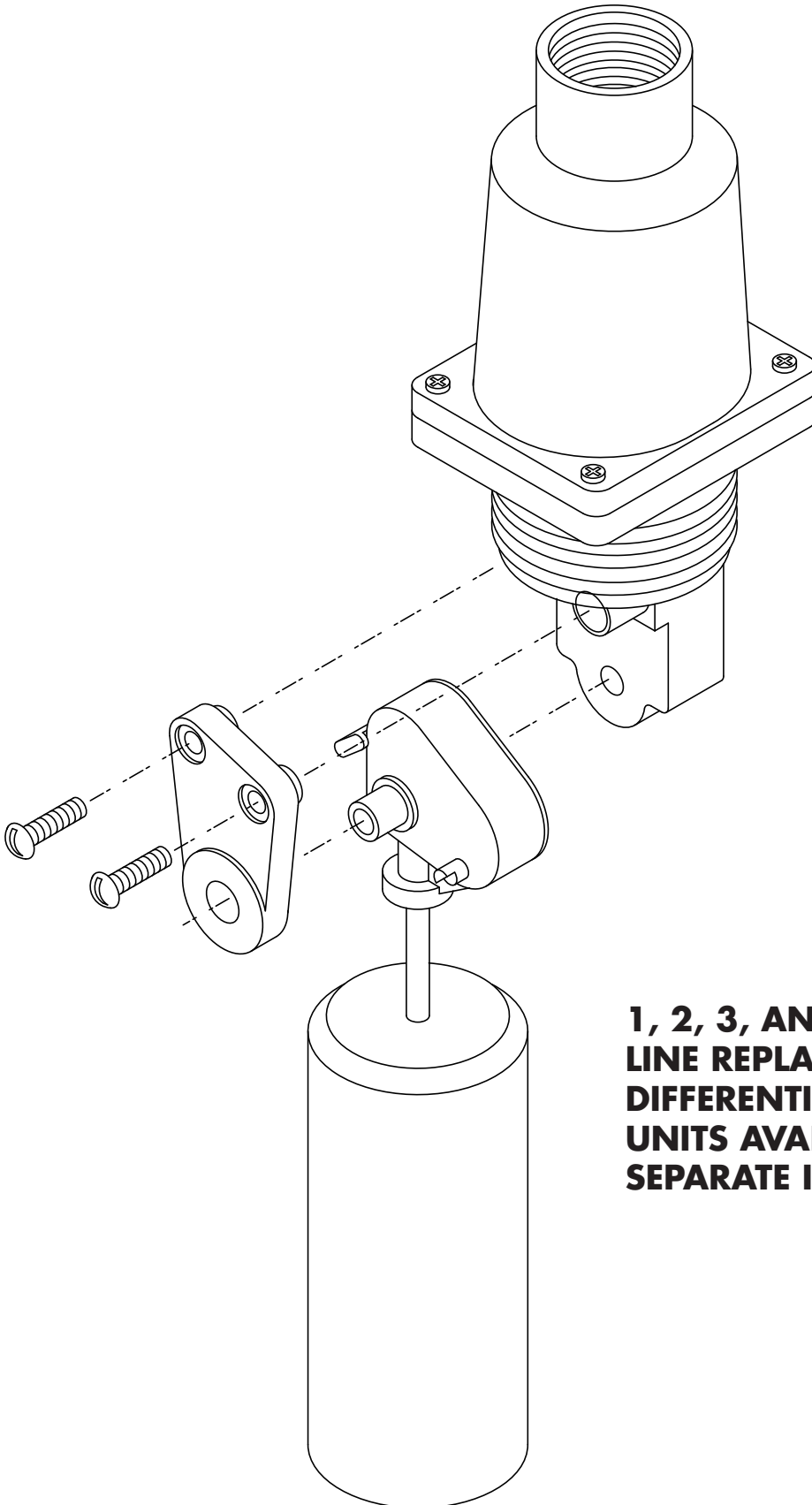

**1, 2, 3, AND 5 INCH
LINE REPLACEABLE
DIFFERENTIAL FLOAT
UNITS AVAILABLE AS
SEPARATE ITEMS.**

MODEL L-21

HARWIL CORPORATION

541 KINETIC DRIVE, OXNARD, CA 93030

TEL: (805) 988-6800 FAX: (805) 988-6804

EMAIL: HARWIL@HARWIL.COM

L-21N (Series 21300)

#	PART NAME	QTY	PART #	#	PART NAME	QTY	PART #
1	STRAIN RELIEF NUT	(1)	60127	9	MAGNET HOUSING (ASSEMBLY ONLY)	(1)	21306
2	GROMMET				1.0" CERAMIC MAGNET (OPT)	(1)	21307
	#A BUNA N (OPTIONAL)	(1)	10440		2.0" CERAMIC MAGNET (OPT)	(1)	21308
	#AA BUNA N (OPTIONAL)	(1)	10441		3.0" CERAMIC MAGNET (OPT)	(1)	21309
	#B BUNA N (OPTIONAL)	(1)	10442		5.0" CERAMIC MAGNET (OPT)	(1)	21310
	#C BUNA N (OPTIONAL)	(1)	10443	10	SHAFT - 316 STAINLESS STEEL	(1)	21311
3	COVER (MALE) NORYL (OPTIONAL)	(1)	60125	11	FLOAT - NORYL	(1)	65601
4	COVER (FEMALE) NORYL (OPTIONAL)	(1)	60126	12	FLOAT - POLYPROPYLENE (OPT)	(1)	65602
5	SCREW	(4)	109-S	13	O-RING	(1)	65110
6	MICROSWITCH (ASSEMBLY ONLY)	(1)	21301	14	SCREW	(2)	147-S
	STEEL PLATE	(1)	21302	15	TERMINALS	(3)	706-T
	CERAMIC MAGNET	(3)	21303	16	SCREW	(2)	101-S
	EPOXY		21350	17	SCREW	(1)	116-S
7	BODY - NORYL (INCL SWITCH BRACKET)	(1)	21304	18	SCREW	(1)	104-S
8	PIVOT SUPPORT	(1)	21305	19	NUT	(1)	202-N

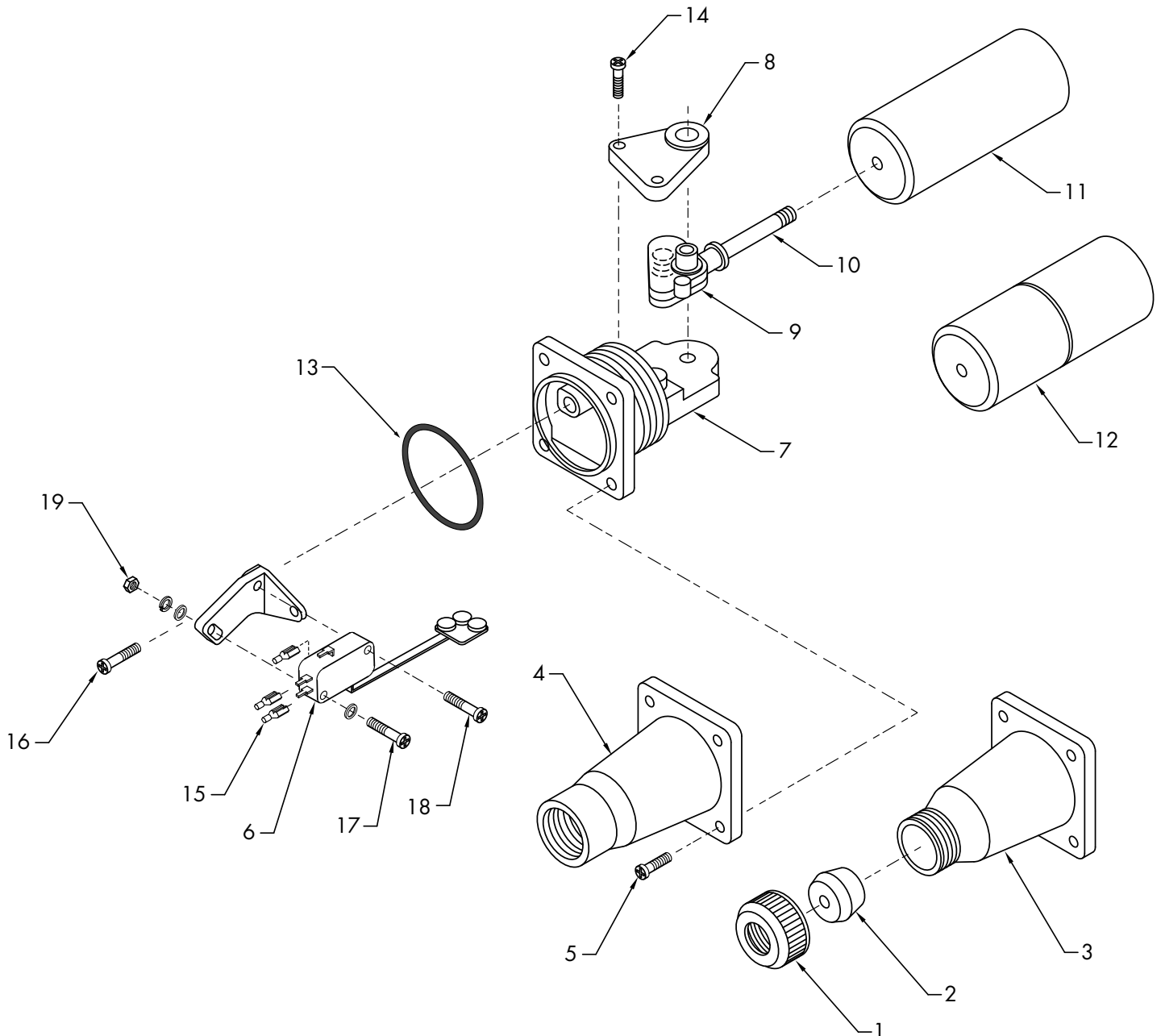

MODEL L-21

HARWIL CORPORATION

541 KINETIC DRIVE, OXNARD, CA 93030

TEL: (805) 988-6800 FAX: (805) 988-6804

EMAIL: HARWIL@HARWIL.COM

L-21R (Series 21400)

#	PART NAME	QTY	PART #	#	PART NAME	QTY	PART #
1	STRAIN RELIEF NUT - FORTRON	(1)	65301	9	MAGNET HOUSING (ASSEMBLY ONLY)	(1)	21403
2	GROMMET				1.0" CERAMIC MAGNET (OPT)	(1)	21307
	#A BUNA N (OPTIONAL)	(1)	10440		2.0" CERAMIC MAGNET (OPT)	(1)	21308
	#AA BUNA N (OPTIONAL)	(1)	10441		3.0" CERAMIC MAGNET (OPT)	(1)	21309
	#B BUNA N (OPTIONAL)	(1)	10442		5.0" CERAMIC MAGNET (OPT)	(1)	21310
	#C BUNA N (OPTIONAL)	(1)	10443	10	SHAFT - 316 STAINLESS STEEL	(1)	21311
3	COVER (MALE) FORTRON (OPTIONAL)	(1)	65302	11	FLOAT - FORTRON	(1)	65805
4	COVER (FEMALE) FORTRON (OPTIONAL)	(1)	65303	12	FLOAT - POLYPROPYLENE (OPT)	(1)	65602
5	SCREW	(4)	109-S	13	O-RING	(1)	65110
6	MICROSWITCH (ASSEMBLY ONLY)	(1)	21301	14	SCREW	(2)	147-S
	STEEL PLATE	(1)	21302	15	TERMINALS	(3)	706-T
	CERAMIC MAGNET	(3)	21303	16	SCREW	(2)	101-S
	EPOXY		21350	17	SCREW	(1)	116-S
7	BODY - FORTRON (INCL SWITCH BRACKET)	(1)	21401	18	SCREW	(1)	104-S
8	PIVOT SUPPORT	(1)	21402	19	NUT	(1)	202-N

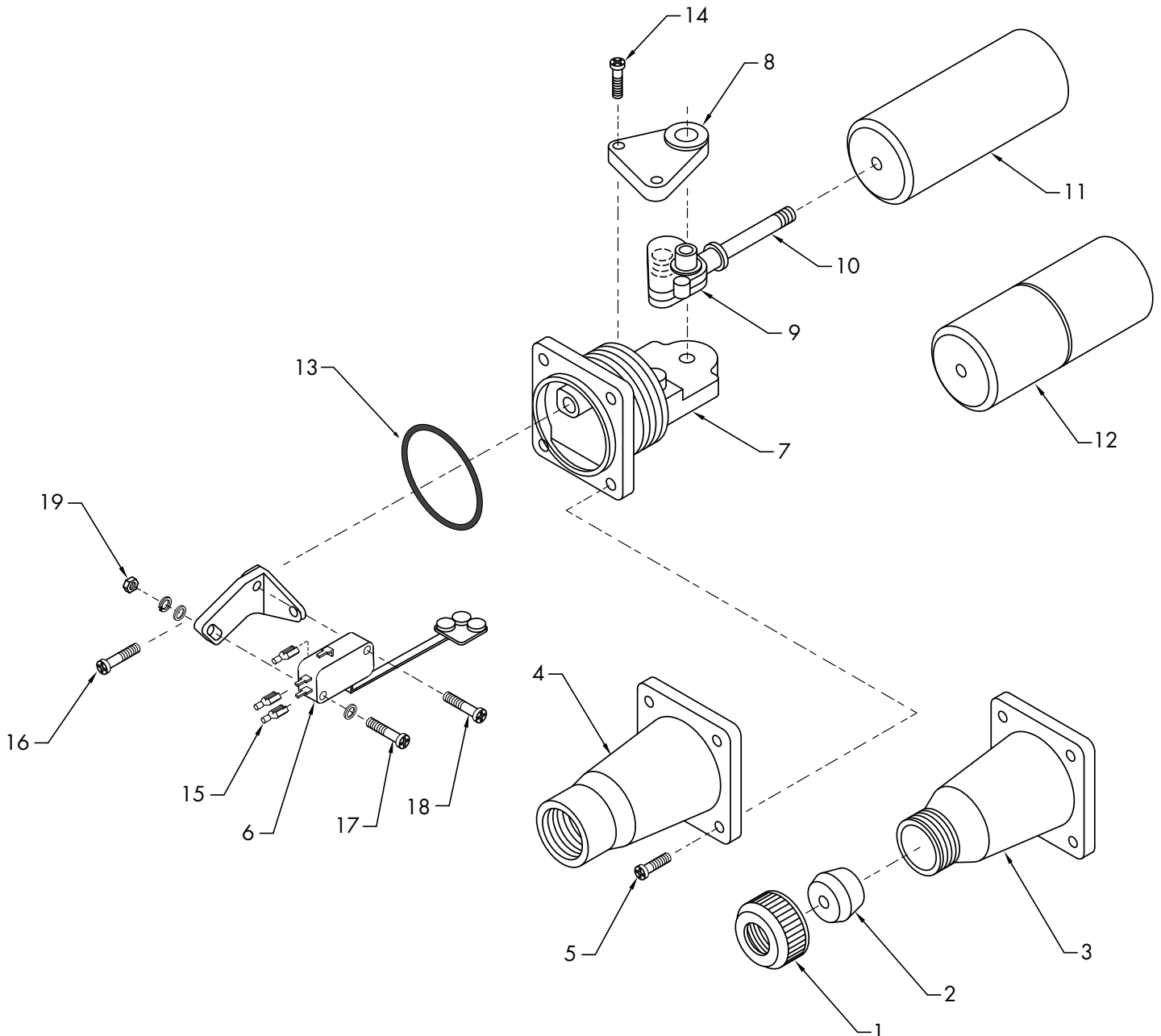

MODEL L-21

HARWIL CORPORATION

541 KINETIC DRIVE, OXNARD, CA 93030

TEL: (805) 988-6800 FAX: (805) 988-6804

EMAIL: HARWIL@HARWIL.COM

L-21VCR (Series 21500)

#	PART NAME	QTY	PART #	#	PART NAME	QTY	PART #
1	STRAIN RELIEF NUT - FORTRON	(1)	65301	9	MAGNET HOUSING (ASSEMBLY ONLY)	(1)	21403
2	GROMMET				1.0" CERAMIC MAGNET (OPT)	(1)	21307
	#A VITON (OPTIONAL)	(1)	65701		2.0" CERAMIC MAGNET (OPT)	(1)	21308
	#B VITON (OPTIONAL)	(1)	65703		3.0" CERAMIC MAGNET (OPT)	(1)	21309
	#C VITON (OPTIONAL)	(1)	65704		5.0" CERAMIC MAGNET (OPT)	(1)	21310
3	COVER (MALE) FORTRON (OPTIONAL)	(1)	65302	10	SHAFT - HASTELLOY C	(1)	21501
4	COVER (FEMALE) FORTRON (OPTIONAL)	(1)	65303	11	FLOAT - FORTRON	(1)	65805
5	SCREW	(4)	109-S	12	FLOAT - POLYPROPYLENE (OPT)	(1)	65602
6	MICROSWITCH (ASSEMBLY ONLY)	(1)	21302	13	O-RING	(1)	65110
	STEEL PLATE	(1)	21302	14	SCREW	(2)	145-S
	CERAMIC MAGNET	(3)	21303	15	TERMINALS	(3)	706-T
	EPOXY		21350	16	SCREW	(2)	101-S
7	BODY - FORTRON (INCL SWITCH BRACKET)	(1)	21407	17	SCREW	(1)	116-S
8	PIVOT SUPPORT	(1)	21402	18	SCREW	(1)	104-S
				19	NUT	(1)	219-N

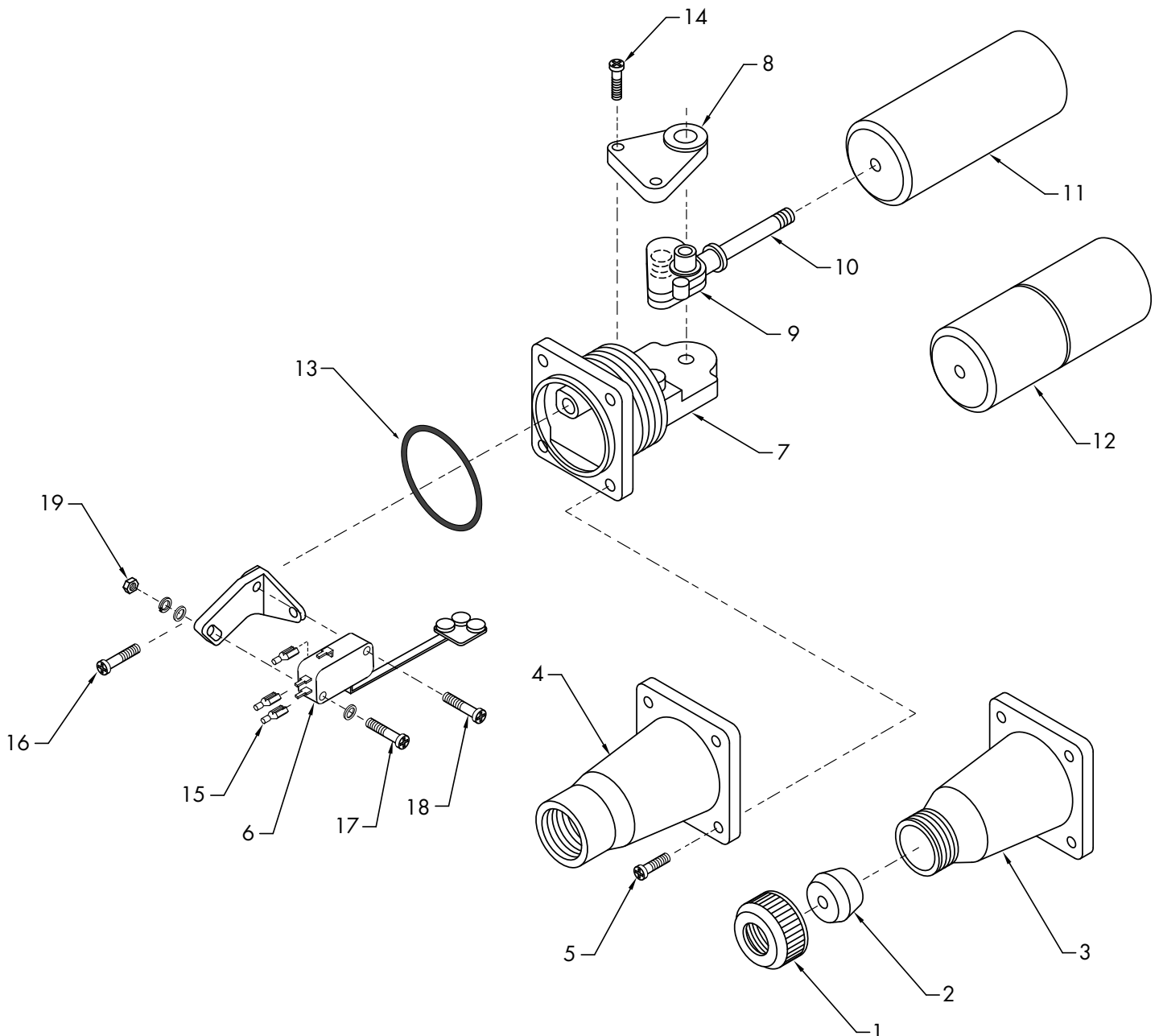

CERTIFICATE OF CONFORMANCE

All HARWIL Corporation ("HARWIL") products are manufactured using new materials and components. Our products meet the applicable performance and materials specifications indicated in our current Specifications Sheets and Parts Lists. HARWIL endeavors to obtain its materials and components from American Companies.

DOMINANCE OF HARWIL LIMITED EXPRESS WARRANTY

HARWIL warrants that all HARWIL products will be free from defects in material and workmanship for a period of one year from the date of original shipment. This warranty shall be limited to the replacement and reconditioning of our products and parts. HARWIL reserves the right and sole discretion to modify or change the composition, design and appearance of its products at anytime.

This warranty shall be in lieu of all warranties of merchantability and of all warranties of fitness for a particular purpose relating to harwil products and parts. Buyer's sole remedy hereunto shall be replacement or reconditioning as set forth herein.

HARWIL shall incur no obligations hereunder and no liability in the event of (a) buyer not fulfilling its responsibilities, including as set forth herein; (b) neglect, alteration or improper product use, including use with non-compatible devices or chemicals; or (c) repair by other than HARWIL. ANY LAWSUIT RELATING TO THIS WARRANTY MUST BE COMMENCED WITHIN ONE YEAR OF THE DATE IT ACCRUES.

Each user of our product should make appropriate analysis and tests to determine the suitability of the product for the intended use prior to purchase. HARWIL provides no warranty and assumes no responsibility for corrosive attack on any material, component or design features associated with any of its products.

Corrosion resistance information listed in HARWIL specification sheets, installation sheets and product brochures is solely for general background information. This table has been compiled from literature published by various material suppliers and by equipment manufacturers who use these materials in their products. Inasmuch as these data are based on tests by entities over which HARWIL has no control, HARWIL does not guarantee or accept responsibility for the accuracy of such tests. When using the table, please remember that in any given case several factors such as concentration, temperature, degrees of agitation and presence of impurities influence the rate of corrosion. The guide is intended, in a general way, to rate materials for resistance to chemicals which contain their usual impurities and for types of equipment in common use. Ratings should be used only as a general guide to first approximation of your material requirements rather than as the final answer.

- When in doubt, test materials before installation.
- After installation, follow up with preventative maintenance and periodic inspection.