

MODEL Q-8

INSTALLATION INSTRUCTION SHEET

HARWIL CORPORATION

541 KINETIC DRIVE, OXNARD, CA 93030

TEL: (805) 988-6800 FAX: (805) 988-6804

EMAIL: HARWIL@HARWIL.COM

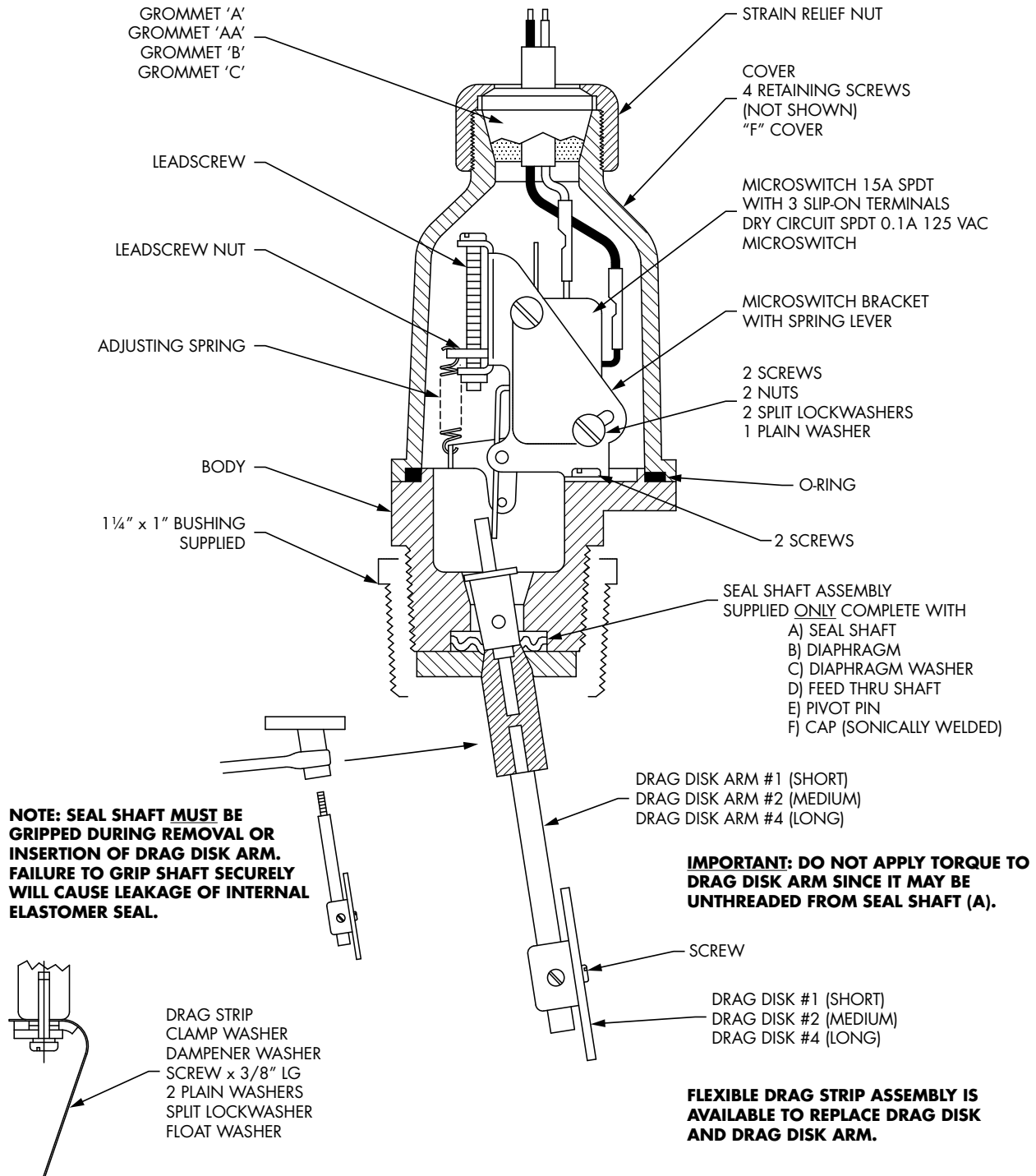

PARTS LIST

FLUID FLOW SWITCH

MODELS
Q-8N

MODEL Q-8

INSTALLATION INSTRUCTION SHEET

HARWIL CORPORATION

541 KINETIC DRIVE, OXNARD, CA 93030
 TEL: (805) 988-6800 FAX: (805) 988-6804
 EMAIL: HARWIL@HARWIL.COM

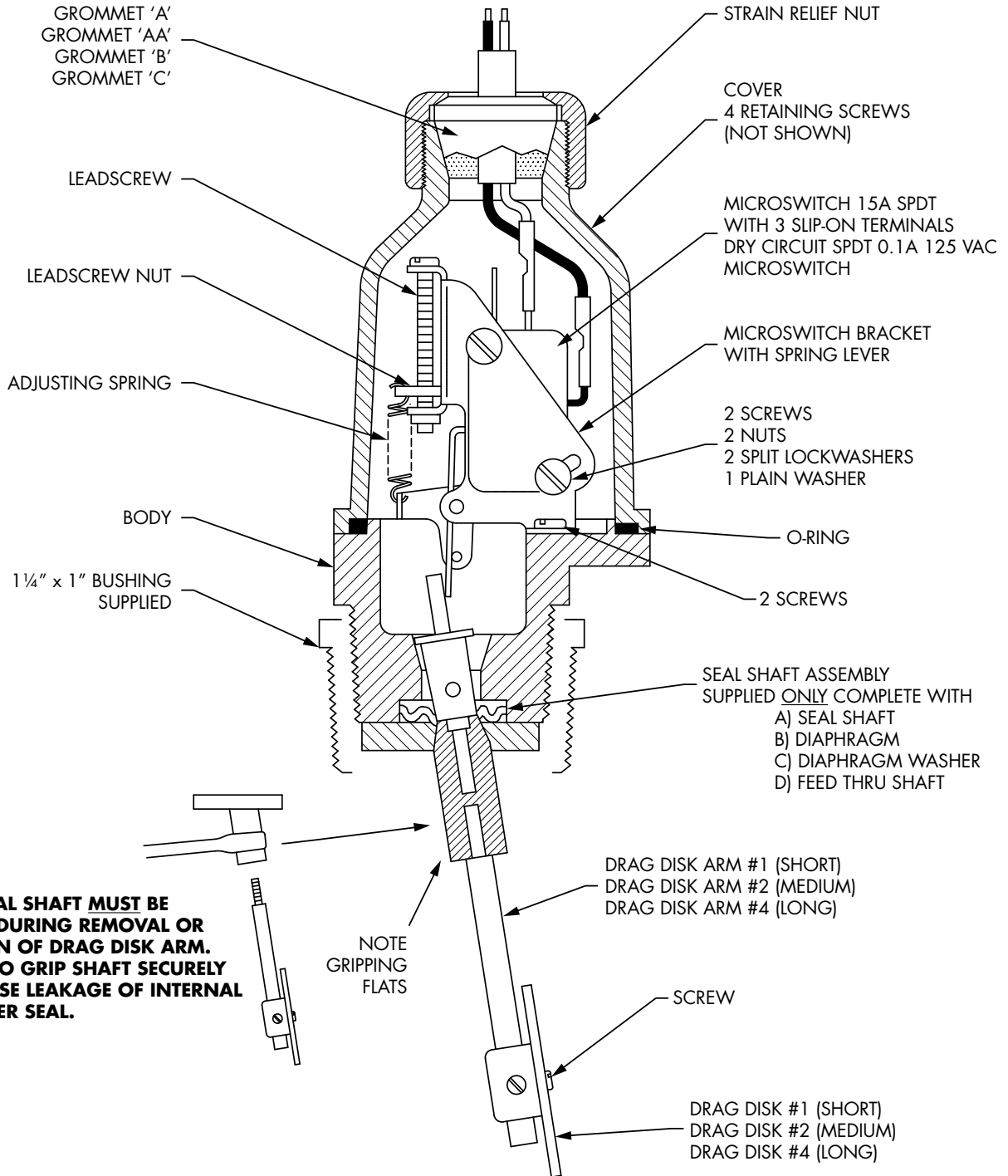

NOTE: SEAL SHAFT MUST BE GRIPPED DURING REMOVAL OR INSERTION OF DRAG DISK ARM. FAILURE TO GRIP SHAFT SECURELY WILL CAUSE LEAKAGE OF INTERNAL ELASTOMER SEAL.

PARTS LIST FLUID FLOW SWITCH

**MODELS
 Q-8CR**

MODEL Q-8

INSTALLATION INSTRUCTION SHEET

HARWIL CORPORATION

541 KINETIC DRIVE, OXNARD, CA 93030
 TEL: (805) 988-6800 FAX: (805) 988-6804
 EMAIL: HARWIL@HARWIL.COM

INSTALLATION AND OPERATING INSTRUCTIONS

The Q-8 fluid flow switch is supplied with a 1 1/4" x 1" PVC TT bushing threaded in place with 2 to 3 wraps of Teflon tape, which must be intact or renewed if bushing and switch are separated before assembly. Care must be exercised when threading the PVC bushing into plastic or metal fittings. Apply a minimum of 2 to a maximum of 3 wraps of Teflon tape to threads of bushing - this is especially important if the unit is to be used in metal fittings where coarse METAL THREADS could gall plastic if not lubricated. The plastic bushing CAN BE CRACKED if the main body of the flow switch is tightened into it FIRST. Cracking will not occur if the bushing is FIRST tightened into the pipe or tank fitting and THEN the Q-8 body is tightened into the bushing.

1. Teflon tape the thread and tighten plastic bushing into pipe or tank fitting.
2. Teflon tape the thread and tighten Q-8 switch into PLASTIC bushing by applying wrench to hexagon section. Repeat steps 1 and 2 until ARROW on body points in the DIRECTION OF FLOW and threads are leak tight.
3. Inspect to make sure drag disk does not touch opposite wall of small diameter pipe.

Plumbers' tools such as pipe wrenches are not recommended. If possible, use a "Rigid" type wrench where the smooth jaws closely fit the hexagon section.

ELECTRICAL WIRING

1. Remove gland nut, grommet, and switch cover.
2. Strip outer jacket of electrical cord back approximately 1 1/4". Strip insulation from individual conductors back approximately 1/4"
3. Slip-on terminals are supplied with each switch. Remove from switch terminals and crimp on or solder to electrical leads.
4. Feed electrical cable through gland nut, grommet, and switch cover as shown.
5. Apply slip-on terminals to appropriate contacts of microswitch. Slide cover down cable and fasten to body of switch with four (4) screws provided. Slide grommet down cable until outer jacket is level with small end of grommet. Push grommet into tapered end of cover. Hold cable jacket to prevent rotation and thread gland nut firmly onto cover.

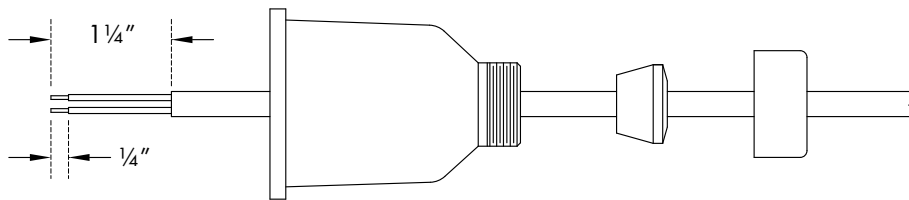
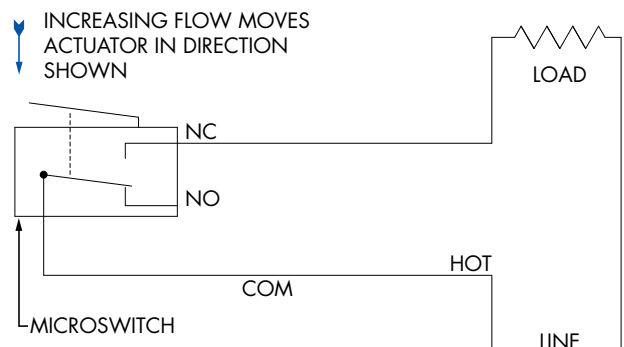
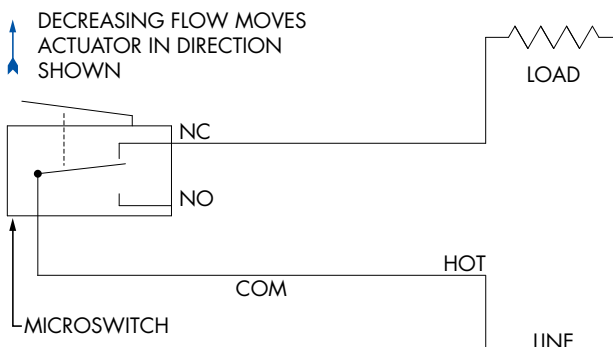

Fig 1: Wiring schematic for power applied to load when flow is less than set point (power to load interrupted when flow increases to above set point).

Fig 2: Wiring schematic for power applied to load when flow is greater than set point (power to load interrupted when flow decreases to below set point).

Decreasing flow moves actuator in direction shown.

Increasing flow moves actuator in direction shown.



SWITCH POINT ADJUSTMENT

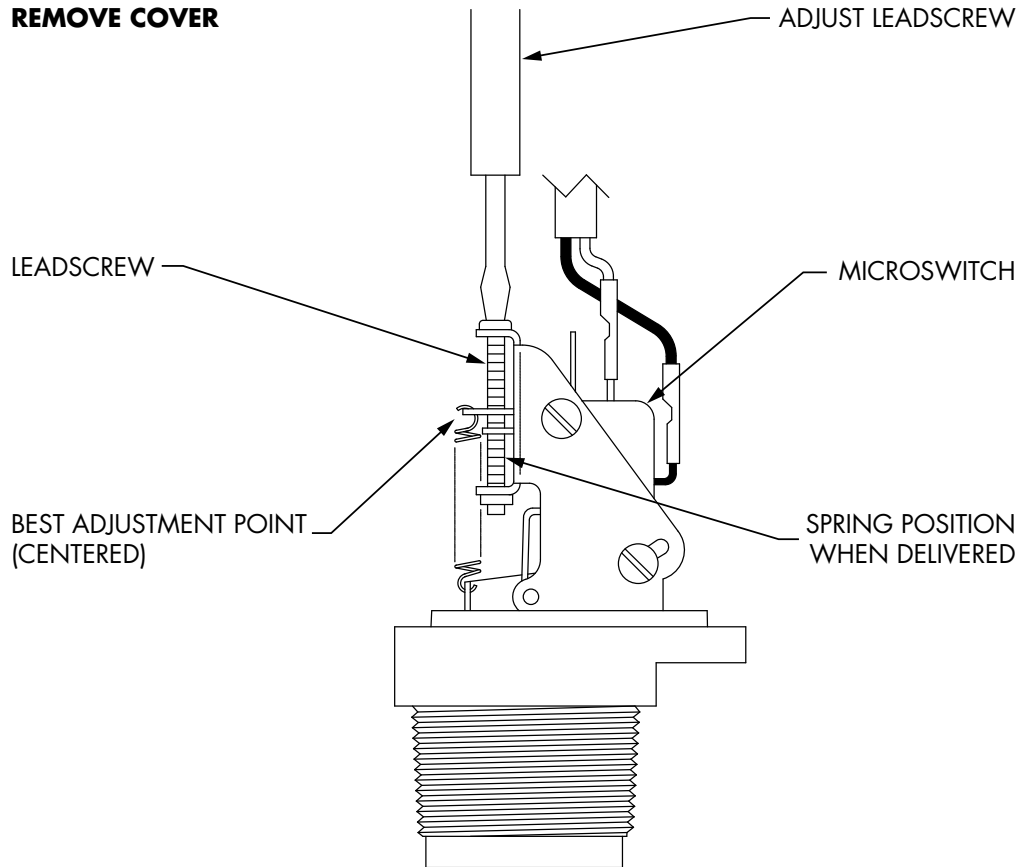

1. Remove cover.
2. Adjust fluid flow in system to desired rate **WITHOUT** regard to Q-8 switch point setting.
3. The switch point adjusting mechanism consists of an adjusting screw, a "U" shaped lead screw nut, and a helical spring.

NOTES:

CLOCKWISE rotation of the adjusting screw changes the microswitch actuation point toward HIGHER flow rates.

All Q-8 units are factory set at the lower end of the flow range, e.g. the adjusting screw is set at the low flow counter-clockwise position.

The lead screw nut locks the adjusting screw in position, maintaining the flow switch set point under all environmental conditions.

4. Turn the adjusting screw in a clockwise direction until the microswitch is actuated, while maintaining the desired fluid flow rate in the system. Turn the adjusting screw TWO (2) additional turns in the

SWITCH POINT ADJUSTMENT (CONTINUED)

clockwise direction and then slowly back off in a counter-clockwise direction, until the microswitch is again actuated. The Q-8 flow switch is now set for maximum sensitivity for detecting small flow changes.

5. When set for maximum sensitivity (100% point) as described in STEP 4, flow turbulence may cause rapid on/off switching (dithering) of the microswitch contacts, resulting in reduced switch contact life and "noise" in the electrical circuit. This is eliminated by turning the adjusting screw in a counter-clockwise direction.
6. Microswitch actuation point may be monitored during the adjustment procedure detailed in STEPS 4 and 5 by an audible click or with an ohmmeter before connecting line power to the terminal strip, or by monitoring the voltage supplied to the load through the microswitch.
7. If the system flow rate is changed, the Q-8 can be adjusted to monitor the new flow rate by turning the adjusting screw in a counter-clockwise direction to the minimum flow position and then proceeding as in STEPS 4 and 5 above.
8. In the event that the system flow is at the desired rate and the adjustment mechanism runs out of travel (e.g., the lead screw nut is at either end of the support bracket before the microswitch is actuated), then the drag disk must be changed to shift the set point range so that it straddles the system flow rate.

MODEL Q-8

INSTALLATION INSTRUCTION SHEET

HARWIL CORPORATION

541 KINETIC DRIVE, OXNARD, CA 93030

TEL: (805) 988-6800 FAX: (805) 988-6804

EMAIL: HARWIL@HARWIL.COM

Q-8N (SERIES 65200)

#	PART NAME	QTY	PART #	#	PART NAME	QTY	PART #
1	STRAIN RELIEF NUT	(1)	60127	17	SCREW	(2)	123-S
2	GROMMET #A (OPTIONAL)	(1)	10440	18	O-RING	(1)	65110
	GROMMET #AA (OPTIONAL)	(1)	10441	19	BODY (ASSEMBLY ONLY)	(1)	65203
	GROMMET #B (OPTIONAL)	(1)	10442		CLAMP RING (SONICALLY WELDED)	(1)	65102
	GROMMET #C (OPTIONAL)	(1)	10443	20	BUSHING REDUCER (OPTIONAL)	(1)	65204
3	COVER (MALE) (OPTIONAL)	(1)	60125		BUSHING REDUCER (OPTIONAL)	(1)	65205
4	COVER (FEMALE) (OPTIONAL)	(1)	60126	21	FEED THRU SHAFT (ASSEMBLY ONLY)	(1)	65103
5	SCREW	(4)	109-S		A) SEAL SHAFT	(1)	65104
6	MICROSWITCH	(1)	20103		B) DIAPHRAGM	(1)	65705
7	BRACKET (COMPLETE ASSEMBLY)	(1)	65201		C) DIAPHRAGM WASHER	(1)	65106
	#A CROSS PIN	(1)	65215		D) PIVOT PIN	(1)	65107
	#B SPRING LEVER	(1)	65216		E) CROSS PIN	(1)	65108
8	TERMINALS	(3)	706-T	22	DRAG DISK ARM #1 (OPTIONAL)	(1)	65206
9	SCREW	(1)	133-S		DRAG DISK ARM #2 (OPTIONAL)	(1)	65207
10	SCREW	(1)	116-S		DRAG DISK ARM #3 (OPTIONAL)	(1)	65209
11	NUT	(2)	219-N	23	DRAG DISK #1 (OPTIONAL)	(1)	65210
12	WASHER	(2)	311-W		DRAG DISK #2 (OPTIONAL)	(1)	65211
13	WASHER	(2)	301-W		DRAG DISK #3 (OPTIONAL)	(1)	65212
14	SCREW	(1)	118-S		DRAG DISK #4 (OPTIONAL)	(1)	65213
15	LEAD SCREW NUT	(1)	65214	24	SCREW	(1)	137-S
16	SPRING	(1)	65202				

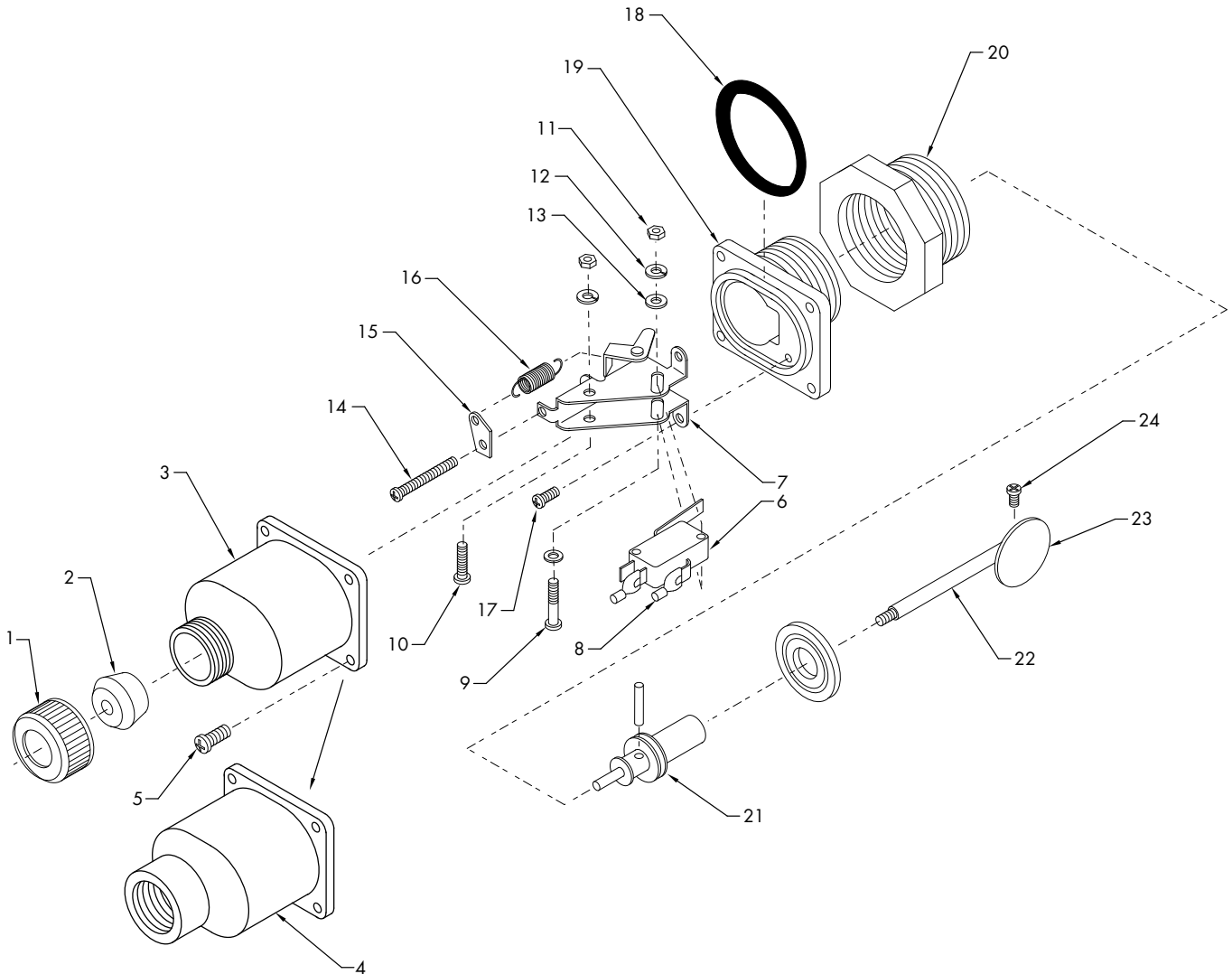

MODEL Q-8

INSTALLATION INSTRUCTION SHEET

HARWIL CORPORATION

541 KINETIC DRIVE, OXNARD, CA 93030

TEL: (805) 988-6800 FAX: (805) 988-6804

EMAIL: HARWIL@HARWIL.COM

Q-8CR (SERIES 65700)

#	PART NAME	QTY	PART #	#	PART NAME	QTY	PART #
1	STRAIN RELIEF NUT	(1)	60301	17	SCREW	(2)	123-S
2	GROMMET #A (OPTIONAL)	(1)	65701	18	O-RING	(1)	65110
	GROMMET #AA (OPTIONAL)	(1)	65702	19	BODY (ASSEMBLY ONLY)	(1)	65304
	GROMMET #B (OPTIONAL)	(1)	65703		CLAMP RING (SONICALLY WELDED)	(1)	65305
	GROMMET #C (OPTIONAL)	(1)	65704	20	BUSHING REDUCER (OPTIONAL)	(1)	65306
3	COVER (MALE) (OPTIONAL)	(1)	65302		BUSHING REDUCER (OPTIONAL)	(1)	65307
4	COVER (FEMALE) (OPTIONAL)	(1)	65303	21	FEED THRU SHAFT (ASSEMBLY ONLY)	(1)	65103
5	SCREW	(4)	109-S		A) SEAL SHAFT	(1)	65104
6	MICROSWITCH	(1)	20103		B) DIAPHRAGM	(1)	65705
7	BRACKET (COMPLETE ASSEMBLY)	(1)	65201		C) DIAPHRAGM WASHER	(1)	65106
	#A CROSS PIN	(1)	65215		D) PIVOT PIN	(1)	65107
	#B SPRING LEVER	(1)	65216		E) CROSS PIN	(1)	65108
8	TERMINALS	(3)	706-T	22	DRAG DISK ARM #1 (OPTIONAL)	(1)	65706
9	SCREW	(1)	133-S		DRAG DISK ARM #2A (OPTIONAL)	(1)	65707
10	SCREW	(1)	116-S		DRAG DISK ARM #2B (OPTIONAL)	(1)	65708
11	NUT	(2)	219-N		DRAG DISK ARM #3 (OPTIONAL)	(1)	65709
12	WASHER	(2)	311-W	23	DRAG DISK #1 (OPTIONAL)	(1)	65210
13	WASHER	(2)	301-W		DRAG DISK #2 (OPTIONAL)	(1)	65211
14	SCREW	(1)	118-S		DRAG DISK #3 (OPTIONAL)	(1)	65212
15	LEAD SCREW NUT	(1)	65214		DRAG DISK #4 (OPTIONAL)	(1)	65213
16	SPRING	(1)	65202	24	SCREW	(1)	137-S

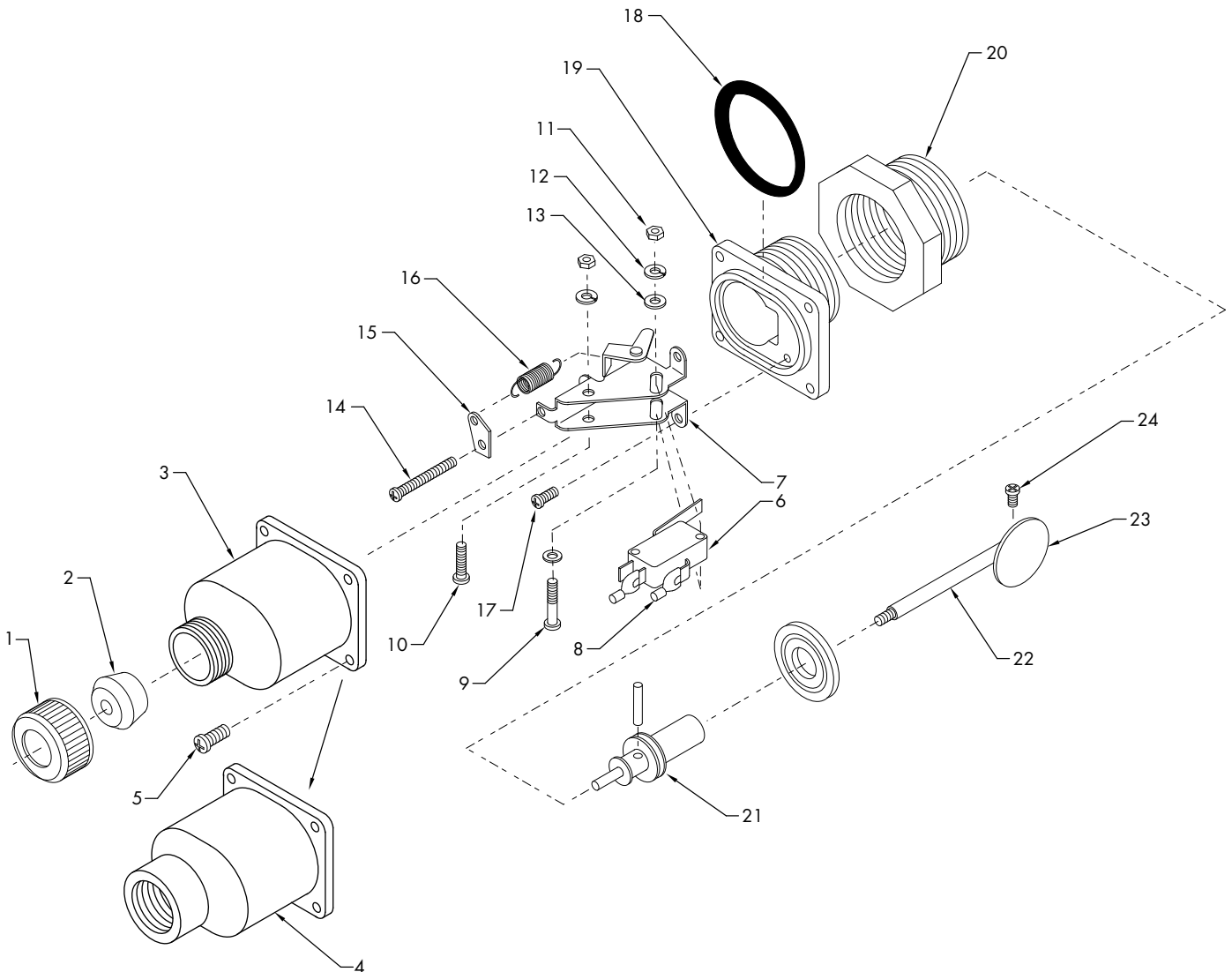

CERTIFICATE OF CONFORMANCE

All Harwil Corporation ("HARWIL") products are manufactured using new materials and components. Our products meet the applicable performance and materials specifications indicated in our current Specifications Sheets and Parts List. HARWIL endeavors to obtain its materials and components from American Companies.

DOMINANCE OF HARWIL LIMITED EXPRESS WARRANTY

Each user **MUST** make appropriate analysis and tests to determine the suitability of the HARWIL product for the intended use prior to purchase.

HARWIL warrants that all HARWIL products will be free from defects in material and workmanship for a period of one year from the date of original shipment. This Warranty shall be **LIMITED** to the replacement and reconditioning of our products and parts. HARWIL reserves the right and sole discretion to modify or change the composition, design and appearance of its products at anytime.

THIS WARRANTY SHALL BE IN LIEU OF ALL WARRANTIES OF MERCHANTABILITY AND OF ALL WARRANTIES OF FITNESS FOR A PARTICULAR PURPOSE RELATING TO HARWIL PRODUCTS AND PARTS. BUYER'S SOLE REMEDY SHALL BE REPLACEMENT OR RECONDITIONING AS SET FORTH HEREIN.

HARWIL SHALL INCUR NO OBLIGATIONS HEREUNDER AND NO LIABILITY IN THE EVENT OF (1) BUYER NOT FULFILLING ITS RESPONSIBILITIES; INCLUDING AS SET FORTH HEREIN; (2) NEGLIGENCE, ALTERATION OR IMPROPER PRODUCT USE, INCLUDING USE WITH NON-COMPATIBLE DEVICES OR CHEMICALS; OR (3) REPAIR BY ANOTHER COMPANY OR PERSON THAN HARWIL.

ANY LAWSUIT RELATING TO THIS LIMITED EXPRESS WARRANTY MUST BE COMMENCED WITHIN ONE YEAR OF THE DATE THE LAWSUIT ACCRUES.

HARWIL provides **NO WARRANTY** and **ASSUMES NO RESPONSIBILITY** for corrosive attack on any material, component or design features associated with any of its products.

Corrosion resistance information listed in HARWIL specification sheets, information sheets and product brochures is solely for general background information. This information table has been compiled from literature published by various material suppliers and by equipment manufacturers who use these materials in their products. Inasmuch as these data are based on tests by entities over which HARWIL has no control, HARWIL **DOES NOT GUARANTEE AND DOES NOT ACCEPT ANY RESPONSIBILITY FOR THE ACCURACY OF SUCH THIRD PARTY TESTING**. When using the table, please remember that in any given case several factors such as concentration, temperature, degrees of agitation and presence of impurities influence the rate of corrosion. The information table is intended, in a general way, to rate materials for resistance to chemicals which contain their usual impurities and for types of equipment in common use. Ratings should be used only as a general tool to first approximation of your material requirements rather than as the final answer.

WHEN IN DOUBT, TEST MATERIALS BEFORE INSTALLATION.

AFTER INSTALLATION, FOLLOW UP WITH SCHEDULED PREVENTATIVE MAINTENANCE AND PERIODIC INSPECTION.