

# AUTOMATIC FLOW SHUT DOWN CONTROL

# Model SDC-101

## The Problem

- Failure to establish programmed flow after pump turn on signal has been applied.
- Failure to maintain proper flow during normal operation due to line clogging, line rupture, incorrect valve positioning, etc.

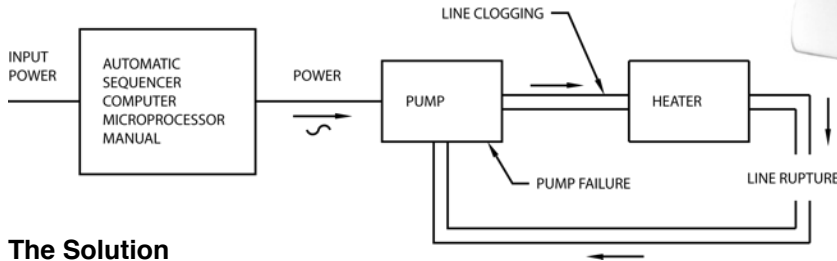

## The Solution

- Insertion of an SDC-101 shut down control in the input power line of pumps, heaters, valves, etc., that are flow critical will interrupt power automatically upon loss of flow.
- Power will remain off until the problem has been corrected and proper flow re-established.
- Loss of pump prime is a persistent fluid system problem. A flow switch at the pump output is a viable solution, except that it presents a “catch 22” situation, i.e. lack of flow at start up will not allow the flow switch to supply power to the pump. A manual push to start or automatic time delay relay switch in parallel with the flow switch is required to supply power to the pump motor during startup. After the pump is up to speed the parallel switch kicks out and the flow switch takes over flow monitoring. Model SDC-101 is provided with a parallel variable time delay relay switch/flow switch combination to provide pump protection during startup as well as the continuous phase of operation.

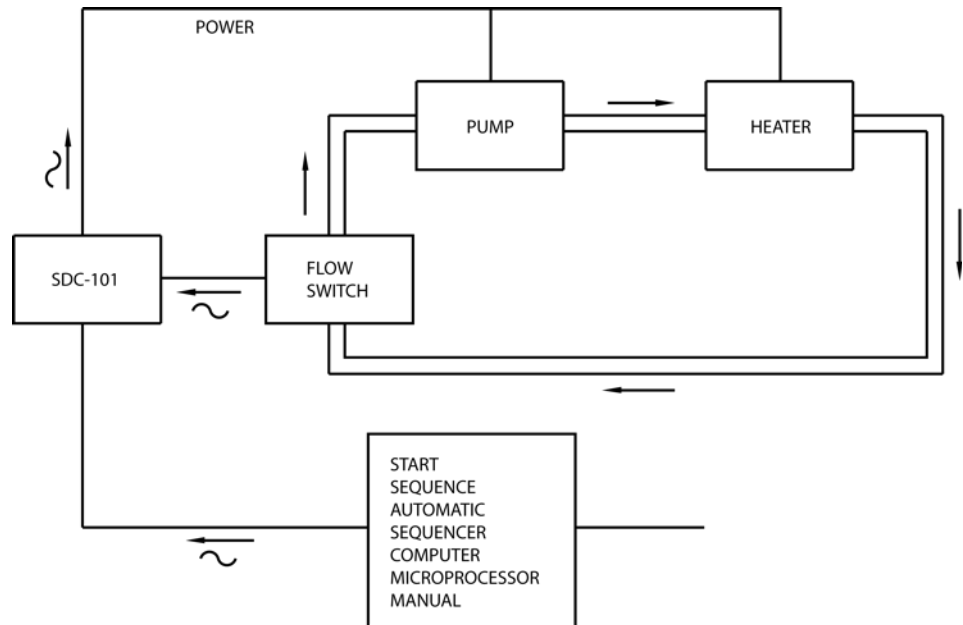

## SDC-101 modules may be connected to monitor:

- Critical points in simple one pump systems or, in series, with pumps, heaters, valves, etc., so that failure of any part will shut the whole system down.
- Isolated or remote components and sub-systems.

## For Use In:

- Chemical process industry
- Sanitation
- Food processing
- Aerospace ground support systems
- Water treatment
- Mining
- Agriculture
- Transportation

## Additional Features:

- Continuous adjustment of time delay cycle.
- 120/240 VAC and DC power options
- Rain resistant housing for rugged, industrial usage
- Can be used in mobile vehicles, ships, trains, etc.

## Operational Features:

- Supplied pre-wired and ready for immediate installation
- All components UL listed or recognized
- Input and output power lines are quickly and easily attached to 30 AMP terminal block
- Terminal block positions are numbered and wiring is color coded for easy, fast and accurate installation and servicing.
- Performance checks are quick and straightforward using an uncomplicated, standard multimeter.



Limited Warranty Page 7

**Specifications:**

**Control Box**

Rain resistant type 3R - UL listed.

# Model SDC-101

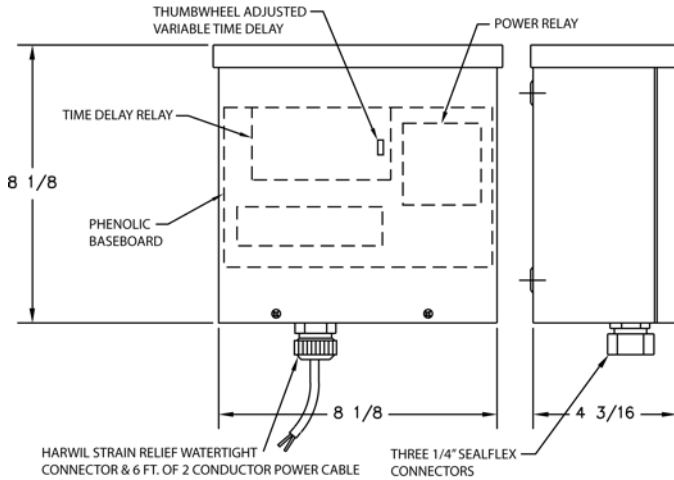

POWER IS SUPPLIED TO THE PUMP IMMEDIATELY ON STARTUP. THE TIME DELAY IS ALSO INITIATED WHICH THEN OPENS HE PARALLEL BYPASS SWITCH AT END OF THE DELAY PERIOD.

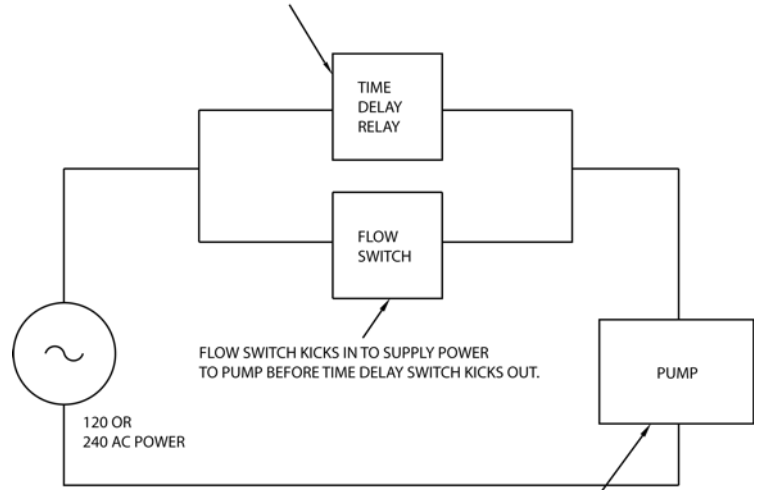

IF PUMP FAILS TO INITIATE FLOW ON STARTUP, PUMP POWER IS IMMEDIATELY SHUT OFF. IF PUMP IS ESTABLISHED AT STARTUP, BUT IS LOST AT A LATER TIME, PUMP POWER IS SHUT OFF.

## Time Delay Relay

### Operation

When rating voltage is applied to the input, the timing cycle begins and the DPDT relay is activated. At the end of the timing cycle, the relay is de-activated and remains in that condition until power is removed from the input. Switching off and then turning on of input power re-starts the timing cycle. This timing sequence will repeat each time the system is turned on.

**Input Voltage - 120/240 VAC, 50/60 Hz**

**Output Contact Arrangement - DPDT**

### Contact Rating

10 AMP, 1/2 HP @ 120/240 VAC, 50/60 Hz

### Standard Time Cycle

1 to 180 sec., Continuously adjustable

**Ambient Operating Temp. Range -5° to 140°F**

**Termination - 1/4" quick disconnect terminals**

## Switch Performance Data

Refer to manufacturer's specification sheets for information regarding performance of:

- Harwil Fluid Flow switches
- Harwil Air Flow switches
- Pressure switches
- Motion Limit switches
- Proximity Switches, etc. which may be used in conjunction with, but are not included with, the SDC-101 module.

**Complete operating instructions. Mechanical and Electrical installation drawing and a numbered parts list is supplied with each unit.**

**Maintenance and checkout is a snap for your present personnel using an uncomplicated standard test meter.**

## Motor Contactor Specifications

### Operating Coil

120 VAC or 208-240 VAC 50/60 Hz  
Inrush: 31 VA  
Continuous Use: 7 VA  
Pickup: 90 VAC (120 VAC Coil)  
170 VAC (208 VA Coil)  
Coil Insulation: class B  
Coil Connections: Double Male 1/4" quick connect  
Maximum Ambient Temperature: 155°

### Output Power Contacts

Type: DPST - Normally Open  
Contact rating per pole.

## Terminal Strip - 812 Series

### Electrical Rating

Rated voltage - 1600 Volts RMS  
Current rating - 30 AMPS

### Wire Size

Will accommodate lugs for wire sizes AWG #14 to #12

### Hardware

Screws and terminals - brass, nickel plated  
Solder terminals - brass, hot-tinned

### Molded Material

G.P. phenolic (94V-0).  
UL Recognized

VOLTS (VAC)	LOCKED ROTOR AMPS (LRA)	FULL LOAD AMPS (FLR)	RESISTIVE AMPS
120/240	100	20	30

VOLTS	MAX NOMINAL MOTOR HORSE POWER
120 VAC	1.5 HP
208-240 VAC	3.0 HP

- Installation drawing and a numbered parts list is supplied with each unit.
- Current Price Information is Listed on Separate Sheet.
- Special One Day Delivery Available.